

basicDIM IPS

SELV power supply

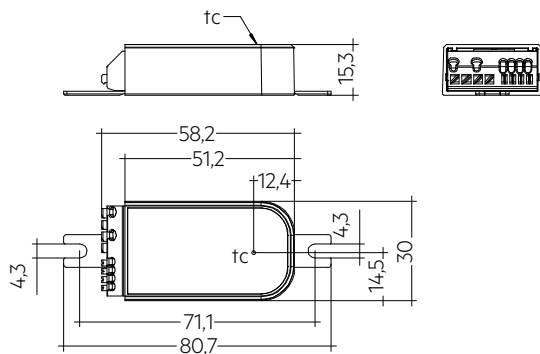

Ordering data

Type	Article number	Packaging, carton	Weight per pc.
basicDIM IPS	87500872	60 pc(s).	0.02 kg

Technical data

Rated supply voltage	220 – 240 V
Mains frequency	50 / 60 Hz
Typ. current ^①	0.0172 A
Power consumption ^①	1.75 W
Typ. power consumption on stand-by ^②	0.31 W
Output DC	16 V
Output power ^①	1.2 W
Max. level voltage DC, SELV	18.4 V
Min. level voltage DC, SELV	13.6 V
Typ. level voltage DC, SELV	16 V
Guaranteed output current, SELV	0.07 A
Max. output current, SELV	105 mA
Ambient temperature t_a	-20 ... +65 °C
Type of protection	IP20
Dimensions L x W x H	80.7 x 30 x 15.3 mm
Lifetime	up to 50,000 h
Guarantee (conditions at www.tridonic.com)	5 Year(s)

Approval marks



Standards

EN 61347-2-11, EN 55015, EN 61000-3-2, EN 61000-3-3, EN 61547, EN 62386-101

^① Test condition at 230 V, 50 Hz and full load.

^② No DALI traffic at the interface.

1. Standards

- EN/IEC 61347-2-11: 2001
- EN 55015: 2013
- EN 61000-3-2: 2014 Part 3-2
- EN 61000-3-3: 2013 Part 3-3
- EN 61547: 2009
- EN 62386-101 Ed.2.1

1.1 Glow-wire test

according to EN 61347-2-11 passed for temperatures up to 850 °C.

2. Common

2.1 Functional description

basicDIM IPS is a SELV power supply, rated at 16 V DC and providing 70 mA for SELV control applications.

The IPS can also be connected to standard non SELV DALI installations and used as standard DALI power supply.

! If the IPS is connected to standard DALI controls which do not provide DALI SELV terminals the whole installation will be non SELV. Conditions for mains voltage have to be fulfilled.

With the provided 70 mA current up to 35 loads can be connected.

! Standard DALI loads are specified to consume max. 2 mA. Some DALI control devices may consume more than 2 mA (e.g. MSensor G3). If such devices are connected to the IPS the amount of possible connected devices will be reduced. This has to be considered during the application design.

Up to 2 IPS can be connected in parallel to provide up to 140 mA.

! Additional IPS must be connected in parallel and the polarity has to be considered. Do not connect more than 2 IPS in one installation. This may cause damage to the device and all other devices connected to the control wires.

The housing provides mounting flaps (manually removable) which can be used for easy installation inside a luminaire.

3. Installation

- For SELV Application the SELV installation regulation do apply.
- For non SELV e.g. standard DALI applications, standard mains voltage regulation do apply.
- The maximum cable length of the output wires must not drop more than 2 V on the signal line voltage.

3.1 Wiring

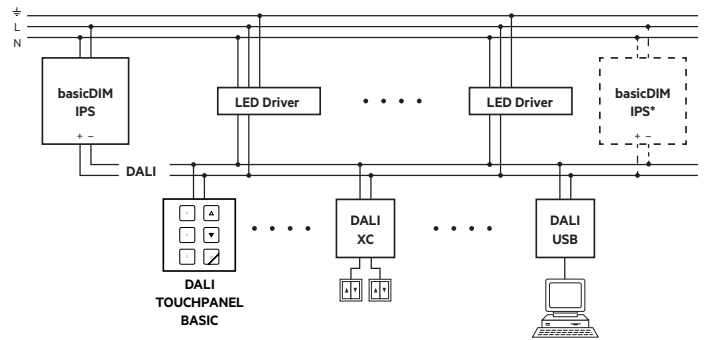

* Possible connection of additional basicDIM IPS

Wiring for SELV applications:

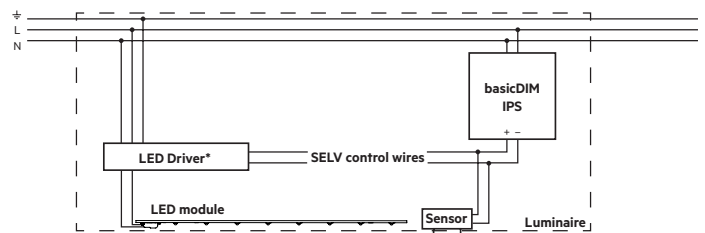

* DALI output of LED driver must be SELV

3.2 Wire types and cross sections

Mains supply wires

For wiring use stranded wire with ferrules or solid wire from 0.2–1.5 mm². Strip 8.5–9.5 mm of insulation from the cables to ensure perfect operation of the push-wire terminals. Use one wire for each terminal connector only.

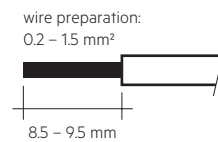

Secondary wires DALI terminals

For wiring use stranded wire with ferrules or solid wire from 0.14–0.5 mm². Strip 7.5–8.5 mm of insulation from the cables to ensure perfect operation of the push-wire terminals. Use one wire for each terminal connector only.

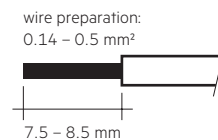

! When loosening the wiring, always use the push-button handle and never pull on the wire until the latch is released.

3.3 Max. output cable length

Material	Cross-section	Max. cable length		
		25 °C	50 °C	75 °C
Copper	0.14 mm ²	31 m	29 m	26 m
	0.20 mm ²	45 m	41 m	37 m
	0.50 mm ²	112 m	102 m	93 m
Aluminium	0.14 mm ²	19 m	17 m	16 m
	0.20 mm ²	27 m	25 m	23 m
	0.50 mm ²	68 m	62 m	57 m

3.4 Output short circuit conditions

The IPS output is short circuit proof. Short circuit behavior has no delay, retry and restart period of shutdown mechanism.

The IPS keeps working even output is short with limited max. output current.

4. Thermal details and lifetime

4.1 Expected lifetime

Expected lifetime				
Type	ta	40 °C	50 °C	65 °C
basicDIM IPS	tc	55 °C	65 °C	75 °C
	Lifetime	>100,000 h	100,000 h	65,000 h

The device is designed for a lifetime stated above under reference conditions and with a failure probability of less than 10 %.

5. Miscellaneous

5.1 Disposal



According to the WEEE directive return old equipment at appropriate collection facilities.

5.2 Additional information

Additional technical information at www.tridonic.com → Technical Data

Guarantee conditions at www.tridonic.com → Services

Lifetime declarations are informative and represent no warranty claim. No warranty if device was opened.