

Product Summary

| | |
|------------------------------|-------------------------------------|
| V_{DS} | 1200 V |
| $I_D (T_c=25^\circ\text{C})$ | 64 A |
| $R_{DS(on),typ}$ | 40 m Ω @ $V_{GS}=18\text{V}$ |

Features

- Low On-Resistance with High Blocking Voltage
- Low Capacitance
- Avalanche Ruggedness
- Halogen Free, Rohs Compliant

Benefits

- High Frequency Operation
- Enabling Higher Switching Frequency
- Increased Power Density
- Reduction of Heat Sink Requirements

Applications

- Switch Mode Power Supplies (SMPS)
- Power Inverter & Solar Inverter
- Motor Drivers & EV Charging Station
- DC/DC Converter

Package Pin Definitions

- Pin1 - Gate
- Pin2 - Drain
- Pin3 - Source

Package Parameters

| Part Number | Marking | Package |
|-------------|------------|----------|
| B3M040120H | B3M040120H | TO-247-3 |

Package: TO-247-3

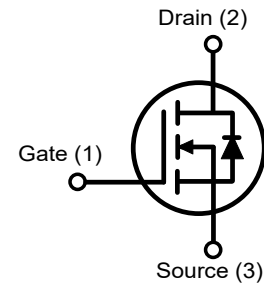
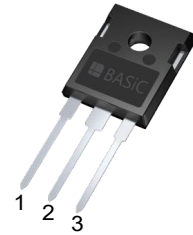

Maximum Ratings

| Symbol | Parameter | Test conditions | Value | Unit |
|------------------|--------------------------------|--|---------|------------|
| V_{DSmax} | Drain-Source Voltage | $V_{GS}=0V, I_D=100\mu A$ | 1200 | V |
| $V_{GSmax}^{1)}$ | Gate-Source Voltage | | -8/22 | V |
| V_{GSop} | Recommend Gate-Source Voltage | | -4/18 | V |
| I_D | Continuous Drain Current | $V_{GS}=18V, T_C=25^\circ C$ | 64 | A |
| | | $V_{GS}=18V, T_C=100^\circ C$ | 45 | A |
| $I_{D,pulse}$ | Pulsed Drain Current | Pulse with t_p limited by T_{jmax} | 124 | A |
| P_{tot} | Power Dissipation | $T_C=25^\circ C, T_j=175^\circ C$ | 312 | W |
| T_j | Operating Junction Temperature | | -55~175 | $^\circ C$ |
| T_{stg} | Storage Temperature | | -55~175 | $^\circ C$ |
| M_d | TO-247 mounting torque | M3 Screw | 0.7 | N·m |

 1) Note: When using MOSFET Body Diode $V_{GSmax}=-4/22V$
Electrical Characteristics (Defined at $T_j=25^\circ C$ unless otherwise specified)
Static Characteristics

| Symbol | Parameter | Test conditions | Value | | | Unit |
|---------------|----------------------------------|---|-------|------|------|------------|
| | | | Min. | Typ. | Max. | |
| $V_{(BR)DSS}$ | Drain-Source Breakdown Voltage | $V_{GS}=0V, I_D=100\mu A$ | 1200 | | | V |
| $V_{GS(th)}$ | Gate Threshold Voltage | $V_{GS}=V_{DS}, I_D=10mA$ (tested after 1ms pulse at $V_{GS}=20V$) | 2.3 | 2.7 | 3.5 | V |
| | | $V_{GS}=V_{DS}, I_D=10mA, T_j=175^\circ C$ (tested after 1ms pulse at $V_{GS}=20V$) | | 1.9 | | |
| I_{GSS} | Gate-Source Leakage Current | $V_{GS}=18V, V_{DS}=0V$ | | | 100 | nA |
| I_{DSS} | Zero Gate Voltage Drain Current | $V_{DS}=1200V, V_{GS}=0V$ | | 1 | 50 | μA |
| | | $V_{DS}=1200V, V_{GS}=0V, T_j=175^\circ C$ | | 10 | 200 | |
| $R_{DS(on)}$ | Drain-Source On-State Resistance | $V_{GS}=18V, I_D=40A$ | | 40 | 55 | m Ω |
| | | $V_{GS}=18V, I_D=40A, T_j=175^\circ C$ | | 75 | | |
| | | $V_{GS}=15V, I_D=40A$ | | 50 | | |
| g_{fs} | Transconductance | $V_{DS}=10V, I_D=40A$ | | 16 | | S |

Thermal Characteristics

| Symbol | Parameter | Value | | | Unit |
|--------------|--|-------|------|------|------|
| | | Min. | Typ. | Max. | |
| $R_{th(jc)}$ | Thermal Resistance from Junction to Case | | 0.48 | 0.70 | K/W |

AC Characteristics

| Symbol | Parameter | Test conditions | Value | | | Unit |
|--------------|--|---|-------|------|------|----------|
| | | | Min. | Typ. | Max. | |
| C_{iss} | Input Capacitance | $V_{GS}=0V, V_{DS}=800V$ $f=100kHz, V_{AC}=25mV$ | | 1870 | | pF |
| C_{oss} | Output Capacitance | | | 82 | | pF |
| C_{rss} | Reverse Transfer Capacitance | | | 6 | | pF |
| E_{oss} | C_{oss} Stored Energy | | | 33 | | μJ |
| $C_{O(ER)}$ | Effective Output Capacitance, Energy Related | $V_{GS}=0V, 0V < V_{DS} < 800V$ | | 105 | | pF |
| $C_{O(TR)}$ | Effective Output Capacitance, Time Related | $V_{GS}=0V, 0V < V_{DS} < 800V$ | | 157 | | pF |
| $R_{G(int)}$ | Internal Gate Resistance | $f=1MHz, V_{AC}=25mV$ | | 1.3 | | Ω |

Gate Charge Characteristics

| Symbol | Parameter | Test conditions | Value | | | Unit |
|----------|-----------------------|--|-------|------|------|------|
| | | | Min. | Typ. | Max. | |
| Q_{GS} | Gate to Source Charge | $V_{DS}=800V$ $I_D=40A$ $V_{GS}=-4/+18V$ | | 27 | | nC |
| Q_{GD} | Gate to Drain Charge | | | 39 | | nC |
| Q_G | Total Gate Charge | | | 85 | | nC |

Switching Characteristics

| Symbol | Parameter | Test conditions | Value | | | Unit |
|--------------|----------------------------------|--|-------|------|------|------|
| | | | Min. | Typ. | Max. | |
| $t_{d(on)}$ | Turn-On Delay Time | | | 39 | | ns |
| t_r | Rise Time | $V_{DC}=800V, V_{GS}=-4/18V$ $I_D=40A, R_{G(ext)}=3.3\Omega$ | | 17 | | ns |
| $t_{d(off)}$ | Turn-Off Delay Time | $L_\sigma=50nH, T_j=25^\circ C$ FWD ²⁾ : body diode at $V_{GS}=-4V$ | | 28 | | ns |
| t_f | Fall Time | Inductive Load Eon includes diode reverse recovery | | 9 | | ns |
| E_{on} | Turn-On Energy (Body Diode FWD) | | | 1100 | | uJ |
| E_{off} | Turn-Off Energy (Body Diode FWD) | | | 160 | | uJ |
| E_{on} | Turn-On Energy (SiC Diode FWD) | $V_{DC}=800V, V_{GS}=-4/18V$ $I_D=40A, R_{G(ext)}=3.3\Omega$ | | 960 | | uJ |
| E_{off} | Turn-Off Energy (SiC Diode FWD) | $L_\sigma=50nH, T_j=25^\circ C$ FWD ²⁾ : B3D20120H | | 160 | | uJ |
| $t_{d(on)}$ | Turn-On Delay Time | | | 36 | | ns |
| t_r | Rise Time | $V_{DC}=800V, V_{GS}=-4/18V$ $I_D=40A, R_{G(ext)}=3.3\Omega$ | | 25 | | ns |
| $t_{d(off)}$ | Turn-Off Delay Time | $L_\sigma=50nH, T_j=175^\circ C$ FWD ²⁾ : body diode at $V_{GS}=-4V$ | | 33 | | ns |
| t_f | Fall Time | Inductive Load Eon includes diode reverse recovery | | 9 | | ns |
| E_{on} | Turn-On Energy (Body Diode FWD) | | | 1500 | | uJ |
| E_{off} | Turn-Off Energy (Body Diode FWD) | | | 190 | | uJ |
| E_{on} | Turn-On Energy (SiC Diode FWD) | $V_{DC}=800V, V_{GS}=-4/18V$ $I_D=40A, R_{G(ext)}=3.3\Omega$ | | 840 | | uJ |
| E_{off} | Turn-Off Energy (SiC Diode FWD) | $L_\sigma=50nH, T_j=175^\circ C$ FWD ²⁾ : B3D20120H | | 180 | | uJ |

2) Note: FWD: Freewheeling diode

Reverse Diode Characteristics

| Symbol | Parameter | Test conditions | Value | | | Unit |
|----------------|----------------------------------|---|-------|------|------|------|
| | | | Min. | Typ. | Max. | |
| V_{SD} | Diode Forward Voltage | $V_{GS}=-4V, I_{SD}=20A, T_j=25^{\circ}C$ | | 5.0 | | V |
| | | $V_{GS}=-4V, I_{SD}=20A, T_j=175^{\circ}C$ | | 4.3 | | |
| I_{SD} | Continuous Diode Forward Current | $V_{GS}=-4V, T_c=25^{\circ}C$ | | 50 | | A |
| $I_{SD,pulse}$ | Pulse Diode Current | $V_{GS}=-4V$, pulse width t_p limited by T_{jmax} | | 125 | | A |
| t_{rr} | Reverse Recovery Time | $V_{GS}=-4V, V_{DC}=800V, I_{SD}=40A$ $-di_F/dt=1400A/\mu s$ $T_j=25^{\circ}C$ | | 31 | | ns |
| Q_{rr} | Reverse Recovery Charge | | | 210 | | nC |
| I_{rrm} | Peak Reverse Recovery Current | | | 10 | | A |
| t_{rr} | Reverse Recovery Time | $V_{GS}=-4V, V_{DC}=800V, I_{SD}=40A$ $-di_F/dt=1600A/\mu s$ $T_j=175^{\circ}C$ | | 40 | | ns |
| Q_{rr} | Reverse Recovery Charge | | | 770 | | nC |
| I_{rrm} | Peak Reverse Recovery Current | | | 29 | | A |

Typical Performance

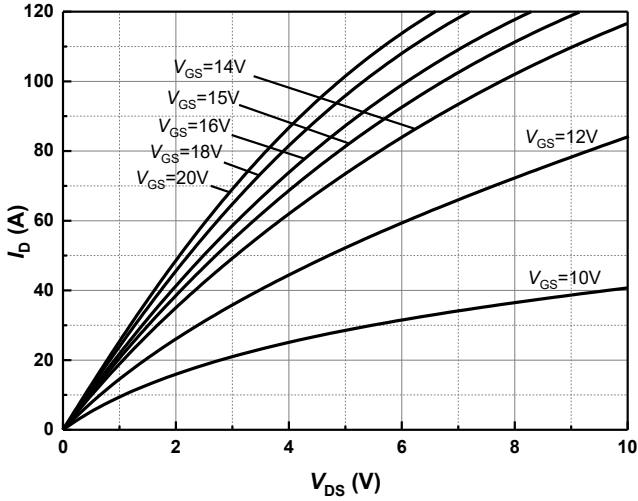

Figure 1 Typical Forward Output Characteristics at $T_j = 25^\circ\text{C}$

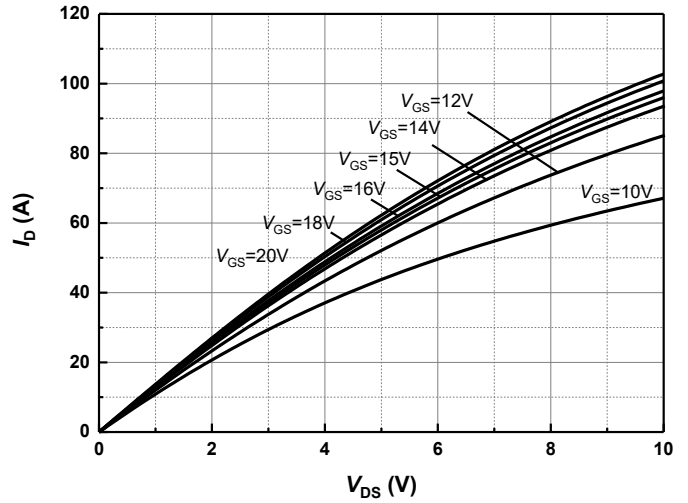

Figure 2 Typical Forward Output Characteristics at $T_j = 175^\circ\text{C}$

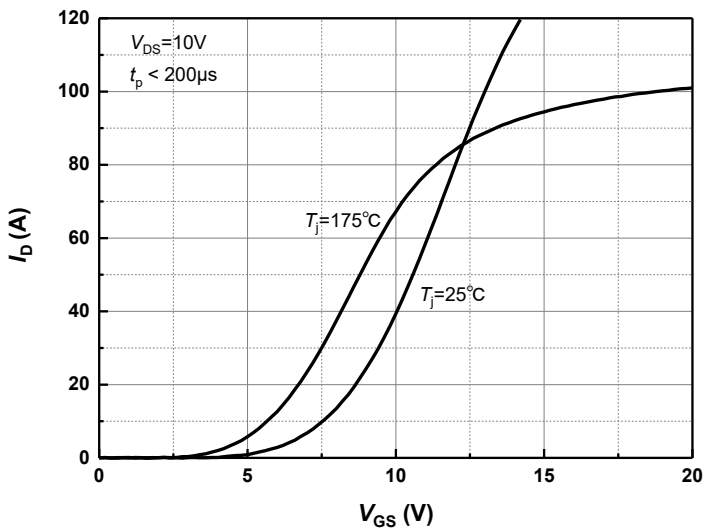

Figure 3 Transfer Characteristics for Various Temperature

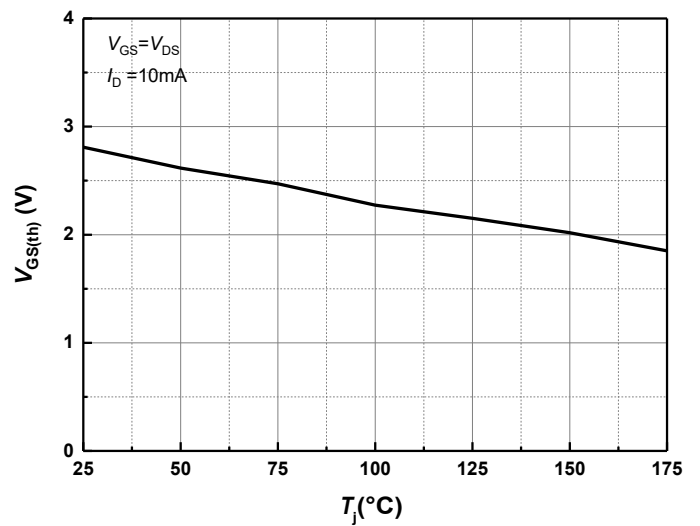

Figure 4 Threshold Voltage for Various Temperature

Typical Performance

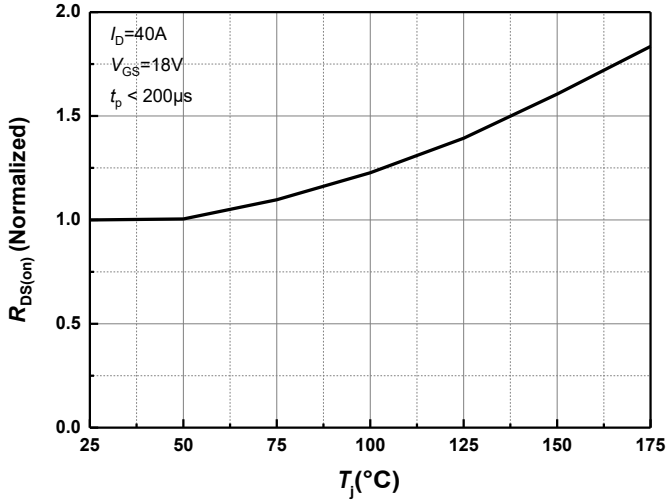

Figure 5 Normalized On-Resistance for Various Temperature

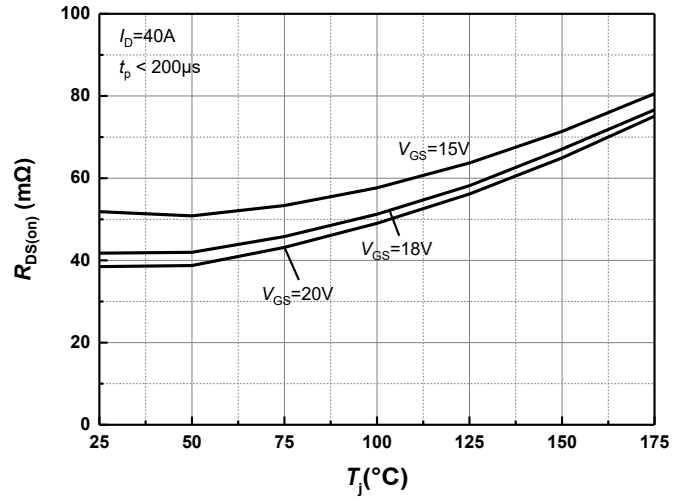

Figure 6 On-Resistance vs. Temperature for Various Gate-Source Voltage

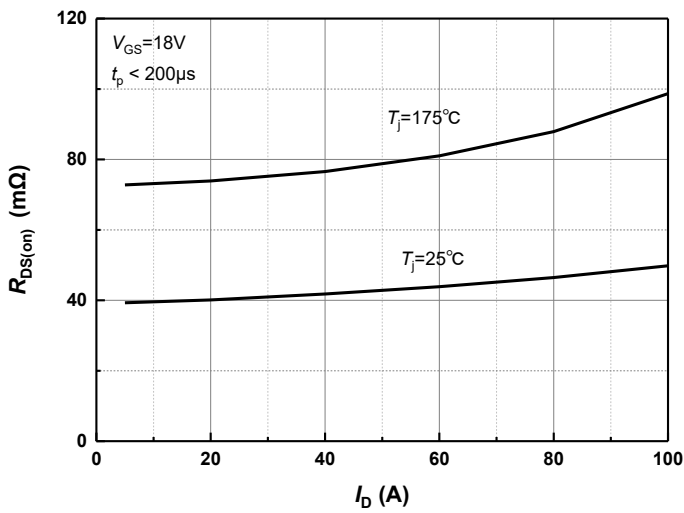

Figure 7 On-Resistance vs. Drain Current for Various Temperature

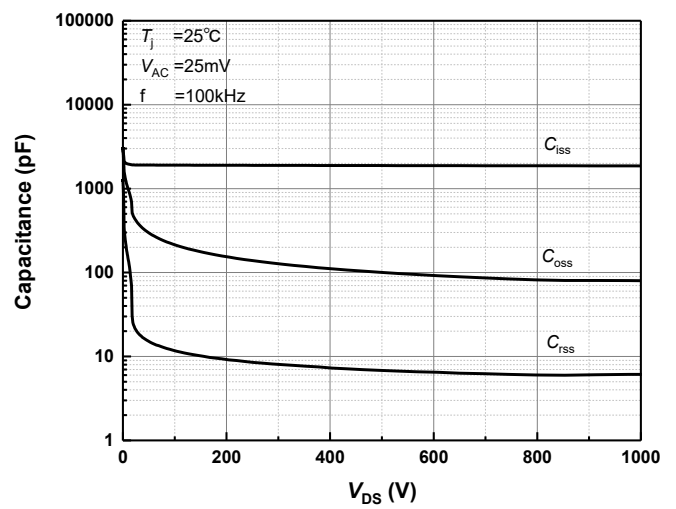

Figure 8 Capacitance vs. Drain-Source Voltage (0 - 1000V)

Typical Performance

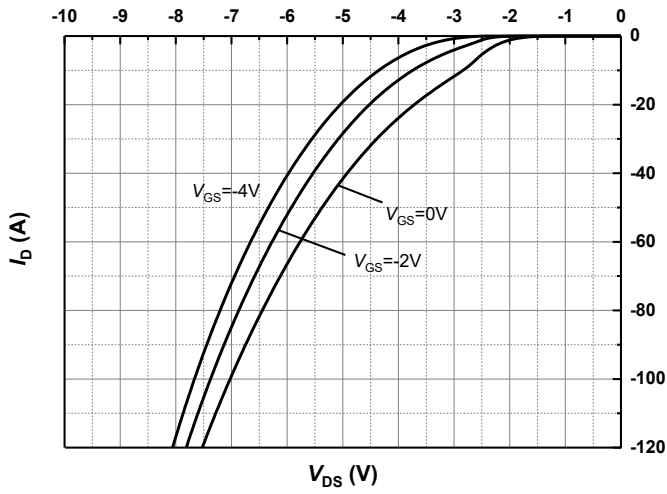

Figure 9 Body Diode Characteristics at $T_j=25^{\circ}\text{C}$

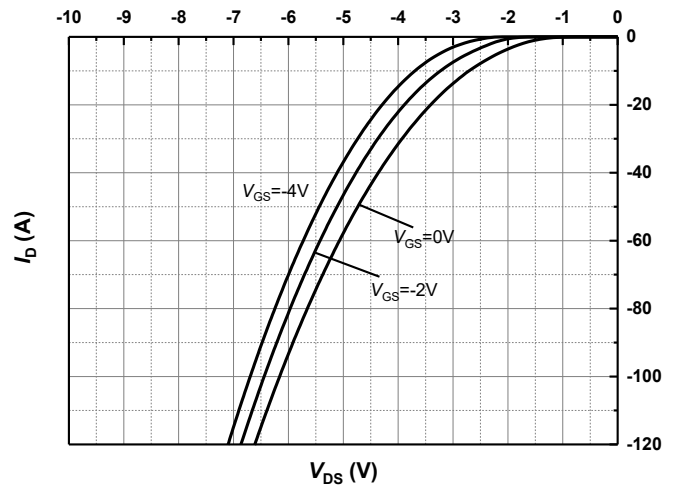

Figure 10 Body Diode Characteristics at $T_j=175^{\circ}\text{C}$

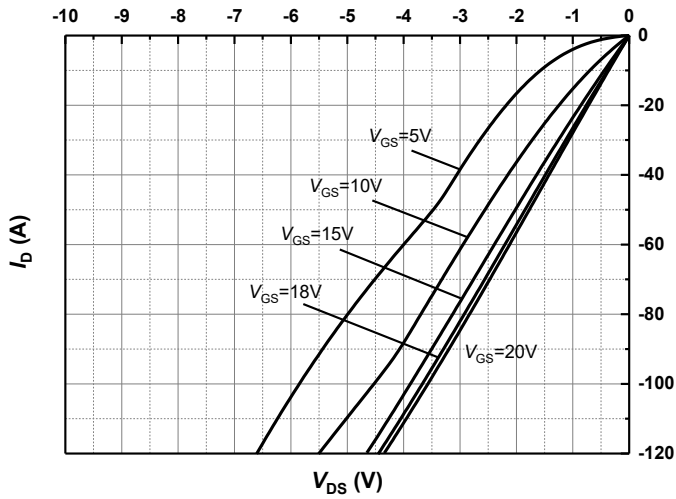

Figure 11 3rd Quadrant Characteristics at $T_j=25^{\circ}\text{C}$

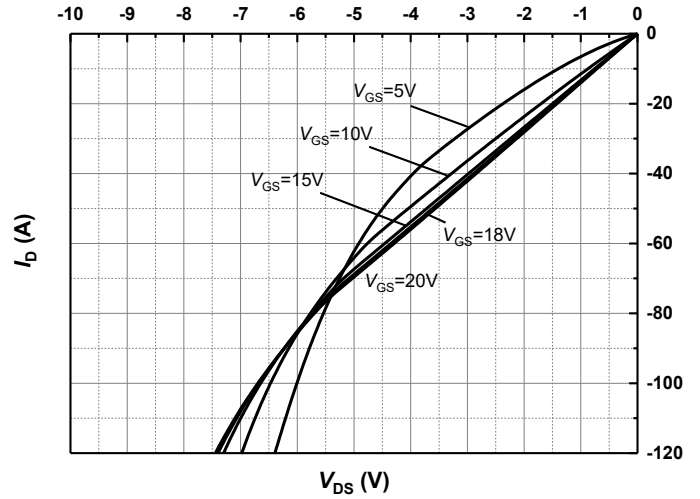

Figure 12 3rd Quadrant Characteristics at $T_j=175^{\circ}\text{C}$

Typical Performance

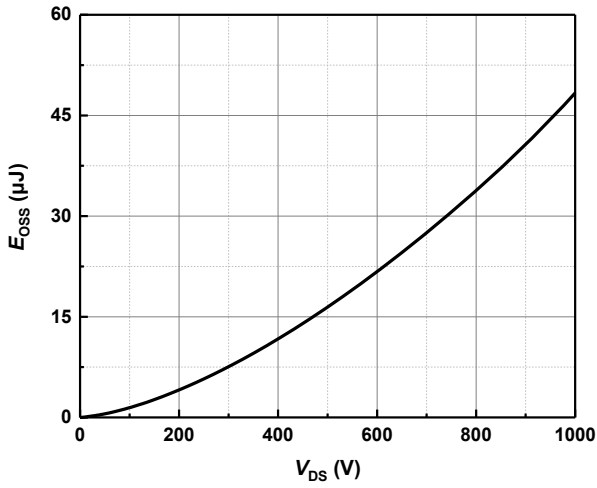

Figure 13 Output Capacitor stored Energy

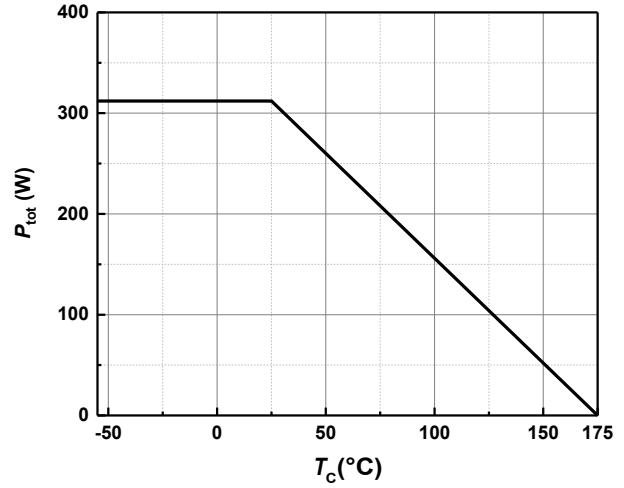

Figure 14 Maximum Power Dissipation Derating vs. Case Temperature

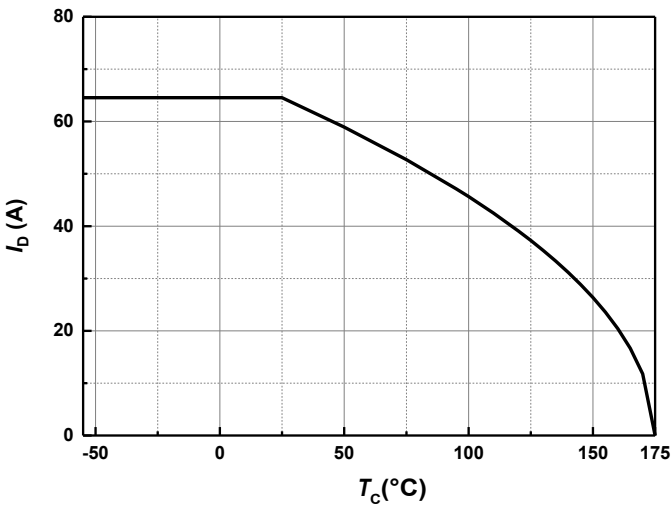

Figure 15 Continuous Drain Current Derating vs. Case Temperature

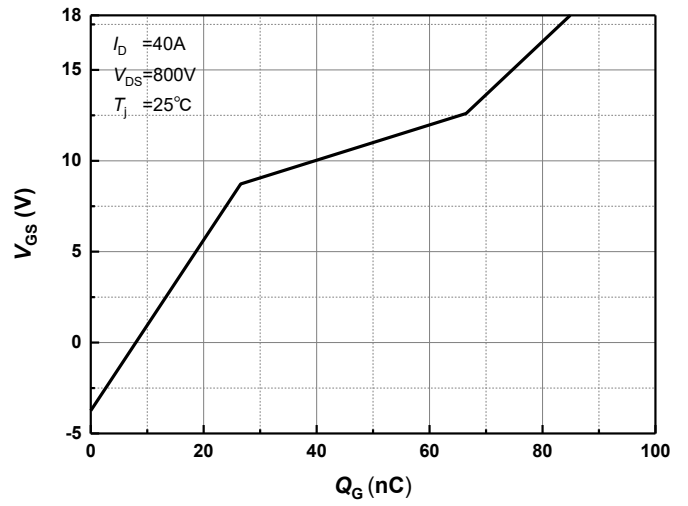

Figure 16 Gate Charge Characteristics

Typical Performance

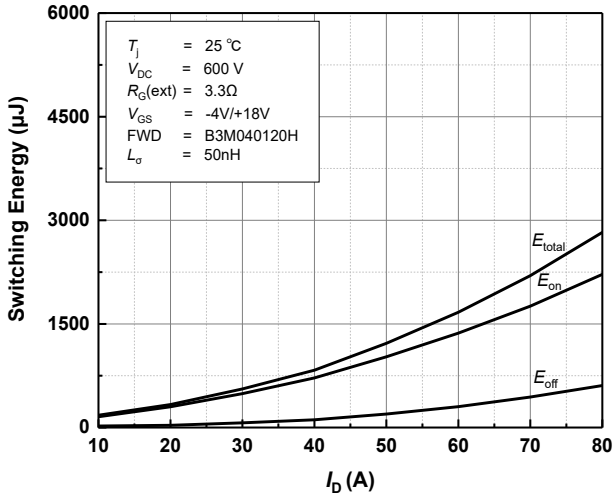

Figure 17 Clamped Inductive Switching Energy vs. Drain Current ($V_{\text{DC}}=600\text{V}$) at $T_j=25^\circ\text{C}$

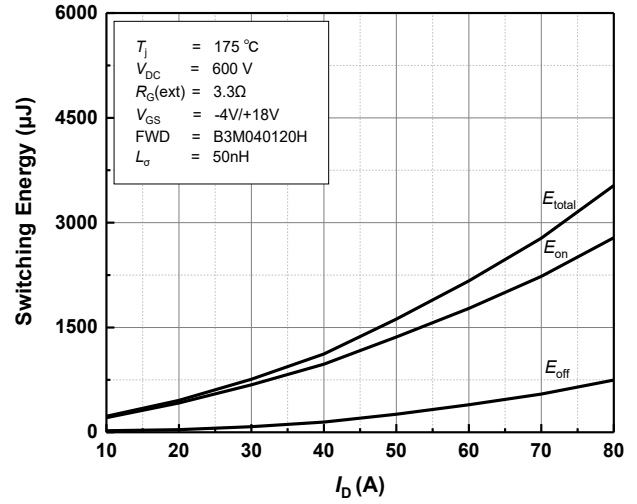

Figure 18 Clamped Inductive Switching Energy vs. Drain Current ($V_{\text{DC}}=600\text{V}$) at $T_j=175^\circ\text{C}$

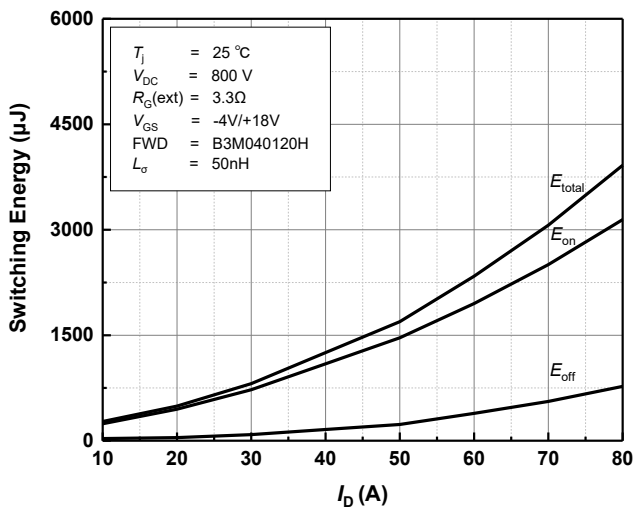

Figure 19 Clamped Inductive Switching Energy vs. Drain Current ($V_{\text{DC}}=800\text{V}$) at $T_j=25^\circ\text{C}$

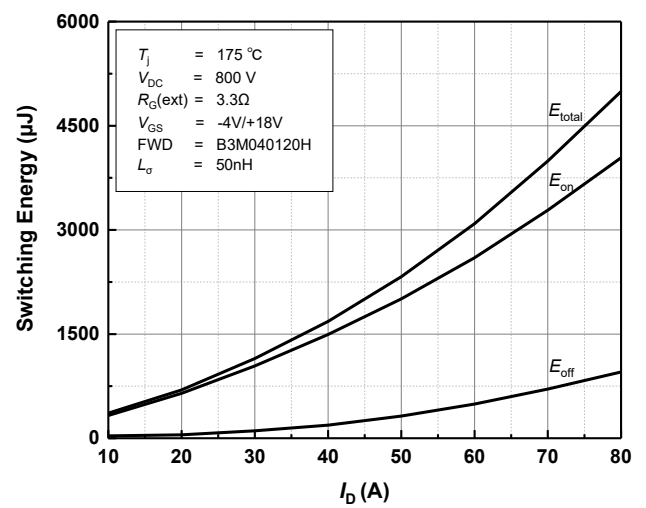

Figure 20 Clamped Inductive Switching Energy vs. Drain Current ($V_{\text{DC}}=800\text{V}$) at $T_j=175^\circ\text{C}$

Typical Performance

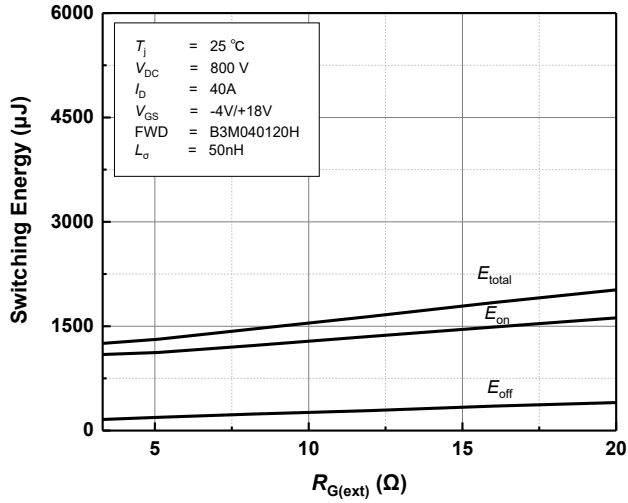

Figure 21 Clamped Inductive Switching Energy vs. External Gate Resistance at $T_j=25^\circ C$

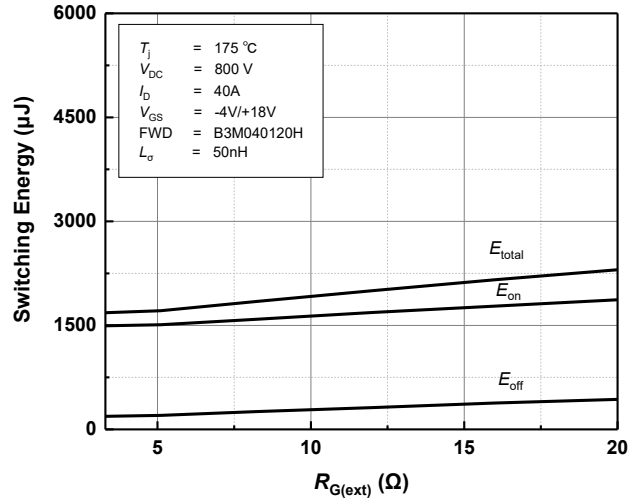

Figure 22 Clamped Inductive Switching Energy vs. External Gate Resistance at $T_j=175^\circ C$

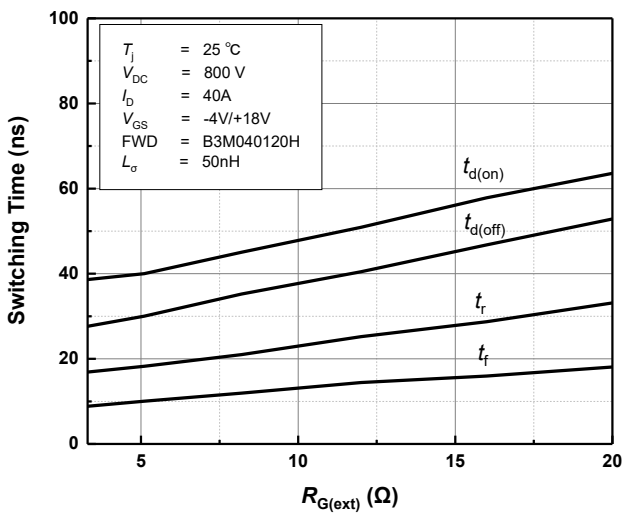

Figure 23 Clamped Inductive Switching Time vs. External Gate Resistance at $T_j=25^\circ C$

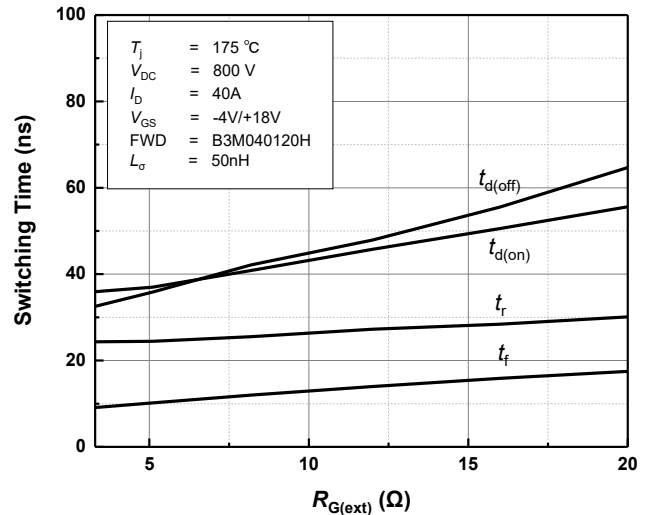

Figure 24 Clamped Inductive Switching Time vs. External Gate Resistance at $T_j=175^\circ C$

Typical Performance

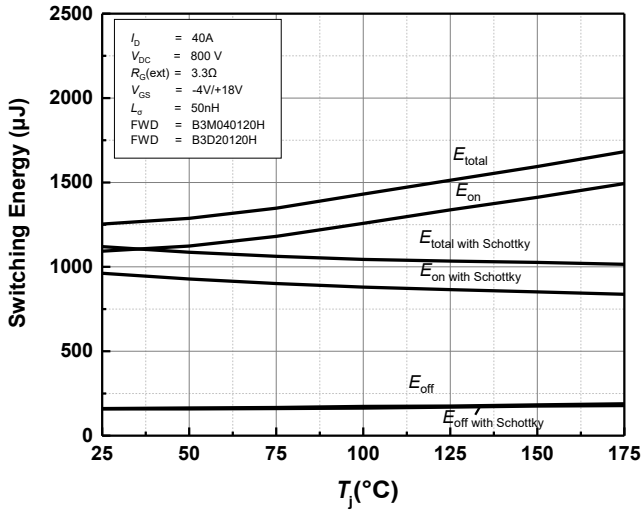

Figure 25 Clamped Inductive Switching Energy vs. Temperature

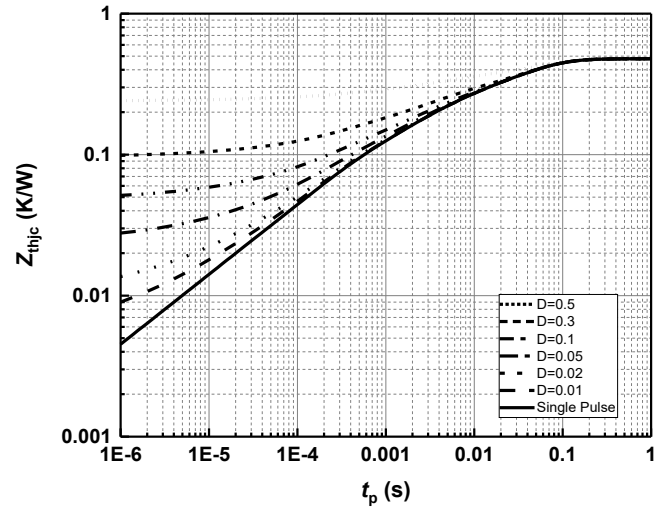

Figure 26 Transient Thermal Impedance (Junction - Case)

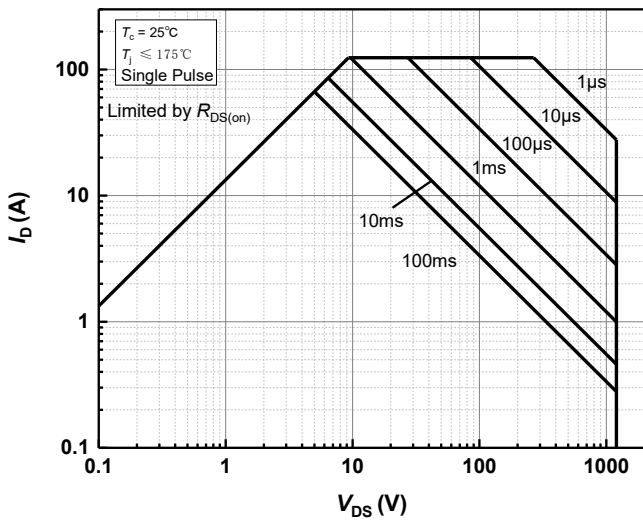
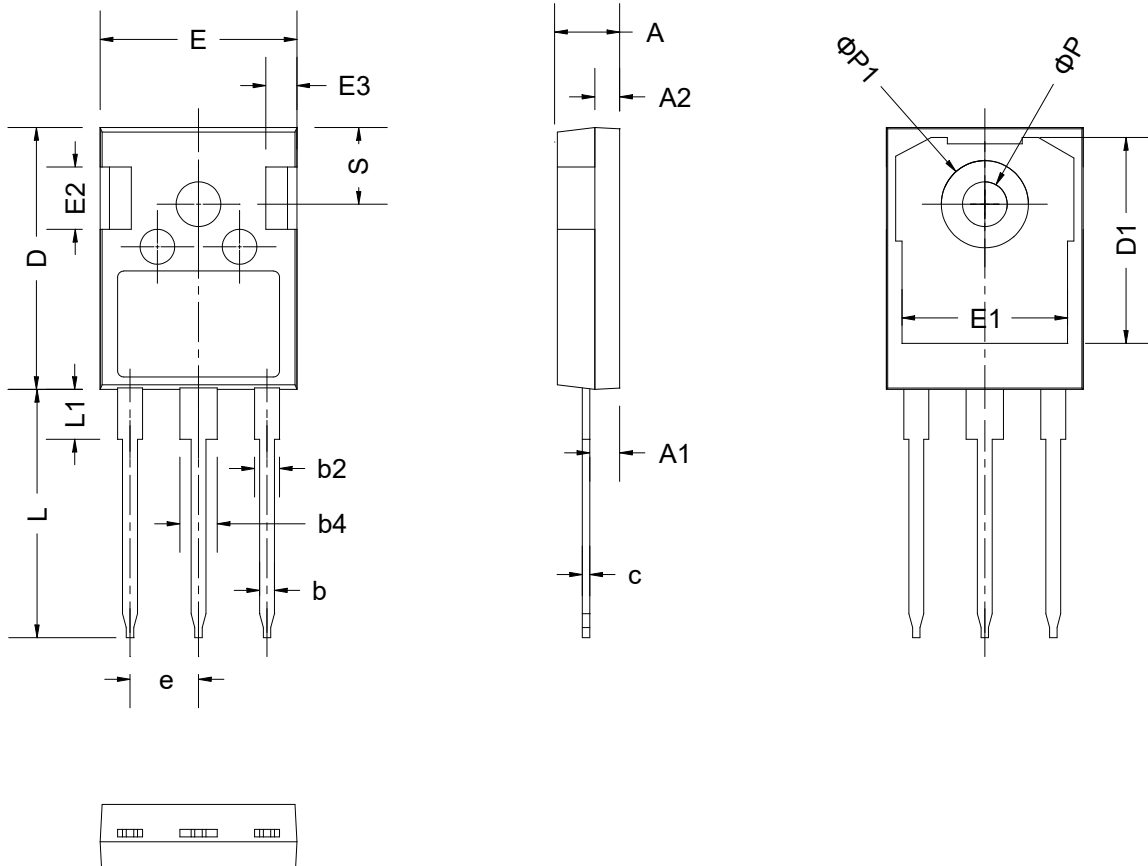

Figure 27 Forward Biased Safe Operating Area

Package Dimensions

| SYMBOL | mm | | |
|--------|----------|-------|-------|
| | MIN | NOM | MAX |
| A | 4.80 | 5.00 | 5.20 |
| A1 | 2.21 | 2.41 | 2.59 |
| A2 | 1.85 | 2.00 | 2.15 |
| b | 1.11 | 1.21 | 1.36 |
| b2 | 1.91 | 2.01 | 2.21 |
| b4 | 2.91 | 3.01 | 3.21 |
| c | 0.51 | 0.61 | 0.75 |
| D | 20.80 | 21.00 | 21.30 |
| D1 | 16.25 | 16.55 | 16.85 |
| E | 15.50 | 15.80 | 16.10 |
| E1 | 13.00 | 13.30 | 13.60 |
| E2 | 4.80 | 5.00 | 5.20 |
| E3 | 2.30 | 2.50 | 2.70 |
| e | 5.44 BSC | | |
| L | 19.62 | 19.92 | 20.22 |
| L1 | - | - | 4.30 |
| φ P | 3.40 | 3.60 | 3.80 |
| φ P1 | - | - | 7.30 |
| S | 6.16 BSC | | |

Revision History

| Document Version | Date of Release | Description of Changes |
|-------------------------|------------------------|-------------------------------|
| Rev. 0.0 | 2024-11-13 | Draft datasheet created. |
| | | |
| | | |
| | | |

BASiC Semiconductor Ltd.
Shenzhen, China
© 2024 BASiC Semiconductor Ltd.
All Rights Reserved.

Information

For further information on technology, delivery terms and conditions and prices, please contact the nearest BASiC Semiconductor Office

Disclaimer

The information given in this document shall in no event be regarded as a guarantee of conditions or characteristics. With respect to any examples or hints given herein, any typical values stated herein and/or any information regarding the application of the device, BASiC semiconductor Ltd. hereby disclaims any and all warranties and liabilities of any kind, including without limitation, warranties of non-infringement of intellectual property rights of any third party.