

### Product Summary

$V_{DS}$	<b>650 V</b>
$I_D (T_C=25^\circ\text{C})$	<b>125 A</b>
$R_{DS(on),typ}$	<b>25 mΩ@<math>V_{GS}=18\text{V}</math></b>

### Features

- Low On-Resistance with High Blocking Voltage
- Low Capacitance
- Avalanche Ruggedness
- Halogen Free, Rohs Compliant

### Benefits

- High Frequency Operation
- Enabling Higher Switching Frequency
- Increased Power Density
- Reduction of Heat Sink Requirements

### Applications

- Switch Mode Power Supplies (SMPS)
- Power Inverter & Solar Inverter
- Motor Drivers & EV Charging Station
- DC/DC Converter

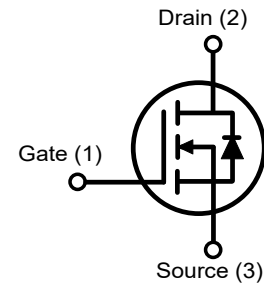
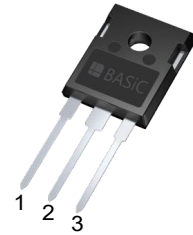
### Package Pin Definitions

- Pin1 - Gate
- Pin2 - Drain
- Pin3 - Source

### Package Parameters

Part Number	Marking	Package
B3M025065H	B3M025065H	TO-247-3

### Package: TO-247-3



**Maximum Ratings**

Symbol	Parameter	Test conditions	Value	Unit
$V_{DSmax}$	Drain-Source Voltage	$V_{GS}=0V, I_D=100\mu A$	650	V
$V_{GSmax}^{1)}$	Gate-Source Voltage		-10/22	V
$V_{GSop}$	Recommend Gate-Source Voltage		-5/18	V
$I_D$	Continuous Drain Current	$V_{GS}=18V, T_C=25^\circ C$	125	A
		$V_{GS}=18V, T_C=100^\circ C$	88	A
$I_{D,pulse}$	Pulsed Drain Current	Pulse with $t_p$ limited by $T_{jmax}$	197	A
$P_{tot}$	Power Dissipation	$T_C=25^\circ C, T_j=175^\circ C$	500	W
$T_j$	Operating Junction Temperature		-55~175	$^\circ C$
$T_{stg}$	Storage Temperature		-55~175	$^\circ C$
$M_d$	TO-247 mounting torque	M3 Screw	0.7	N·m

 1) Note: When using MOSFET Body Diode  $V_{GSmax}=-5/22V$ 
**Electrical Characteristics (Defined at  $T_j=25^\circ C$  unless otherwise specified)**
**Static Characteristics**

Symbol	Parameter	Test conditions	Value			Unit
			Min.	Typ.	Max.	
$V_{(BR)DSS}$	Drain-Source Breakdown Voltage	$V_{GS}=0V, I_D=100\mu A$	650			V
$V_{GS(th)}$	Gate Threshold Voltage	$V_{GS}=V_{DS}, I_D=17mA$ (tested after 1ms pulse at $V_{GS}=20V$ )	2.3	2.7	3.5	V
		$V_{GS}=V_{DS}, I_D=17mA, T_j=175^\circ C$ (tested after 1ms pulse at $V_{GS}=20V$ )		1.9		
$I_{GSS}$	Gate-Source Leakage Current	$V_{GS}=18V, V_{DS}=0V$			100	nA
$I_{DSS}$	Zero Gate Voltage Drain Current	$V_{DS}=650V, V_{GS}=0V$		1	50	$\mu A$
		$V_{DS}=650V, V_{GS}=0V, T_j=175^\circ C$		10	200	
$R_{DS(on)}$	Drain-Source On-State Resistance	$V_{GS}=18V, I_D=50A$		25	40	m $\Omega$
		$V_{GS}=18V, I_D=50A, T_j=175^\circ C$		32		
		$V_{GS}=15V, I_D=50A$		33		
$g_{fs}$	Transconductance	$V_{DS}=10V, I_D=50A$		22		S

**Thermal Characteristics**

Symbol	Parameter	Value			Unit
		Min.	Typ.	Max.	
$R_{th(jc)}$	Thermal Resistance from Junction to Case		0.30		K/W

**AC Characteristics**

Symbol	Parameter	Test conditions	Value			Unit
			Min.	Typ.	Max.	
$C_{iss}$	Input Capacitance	$V_{GS}=0V, V_{DS}=400V$ $f=100kHz, V_{AC}=25mV$		2450		pF
$C_{oss}$	Output Capacitance			180		pF
$C_{rss}$	Reverse Transfer Capacitance			9		pF
$E_{oss}$	$C_{oss}$ Stored Energy			20		$\mu J$
$C_{O(ER)}$	Effective Output Capacitance, Energy Related	$V_{GS}=0V, 0V < V_{DS} < 400V$		250		pF
$C_{O(TR)}$	Effective Output Capacitance, Time Related	$V_{GS}=0V, 0V < V_{DS} < 400V$		365		pF
$R_{G(int)}$	Internal Gate Resistance	$f=1MHz, V_{AC}=25mV$		1.4		$\Omega$

**Gate Charge Characteristics**

Symbol	Parameter	Test conditions	Value			Unit
			Min.	Typ.	Max.	
$Q_{GS}$	Gate to Source Charge	$V_{DS}=400V$ $I_D=50A$ $V_{GS}=-5/+18V$		33		nC
$Q_{GD}$	Gate to Drain Charge			40		nC
$Q_G$	Total Gate Charge			98		nC

**Switching Characteristics**

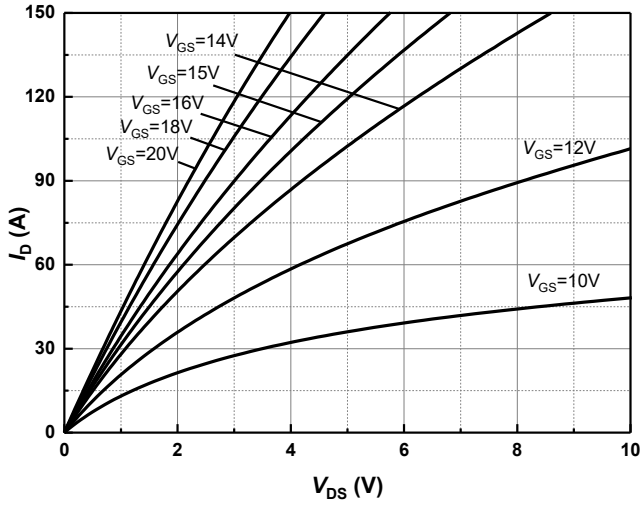
Symbol	Parameter	Test conditions	Value			Unit
			Min.	Typ.	Max.	
$t_{d(on)}$	Turn-On Delay Time			7		ns
$t_r$	Rise Time	$V_{DC}=400V, V_{GS}=-5/18V$ $I_D=50A, R_{G(ext)}=2.2\Omega$		40		ns
$t_{d(off)}$	Turn-Off Delay Time	$L_\sigma=50nH, T_j=25^\circ C$ FWD <sup>2)</sup> : body diode at $V_{GS}=-5V$		25		ns
$t_f$	Fall Time	Inductive Load Eon includes diode reverse recovery		7		ns
$E_{on}$	Turn-On Energy (FWD=Body Diode)			510		$\mu J$
$E_{off}$	Turn-Off Energy (FWD=Body Diode)			120		$\mu J$
$E_{on}$	Turn-On Energy (FWD=SiC SBD)	$V_{DC}=400V, V_{GS}=-5/18V$ $I_D=50A, R_{G(ext)}=2.2\Omega$		430		$\mu J$
$E_{off}$	Turn-Off Energy (FWD=SiC SBD)	$L_\sigma=50nH, T_j=25^\circ C$ FWD <sup>2)</sup> : B3D40065H		127		$\mu J$
$t_{d(on)}$	Turn-On Delay Time			6		ns
$t_r$	Rise Time	$V_{DC}=400V, V_{GS}=-5/18V$ $I_D=50A, R_{G(ext)}=2.2\Omega$		41		ns
$t_{d(off)}$	Turn-Off Delay Time	$L_\sigma=50nH, T_j=175^\circ C$ FWD <sup>2)</sup> : body diode at $V_{GS}=-5V$		29		ns
$t_f$	Fall Time	Inductive Load Eon includes diode reverse recovery		6		ns
$E_{on}$	Turn-On Energy (FWD=Body Diode)			560		$\mu J$
$E_{off}$	Turn-Off Energy (FWD=Body Diode)			140		$\mu J$
$E_{on}$	Turn-On Energy (FWD=SiC SBD)	$V_{DC}=400V, V_{GS}=-5/18V$ $I_D=50A, R_{G(ext)}=2.2\Omega$		385		$\mu J$
$E_{off}$	Turn-Off Energy (FWD=SiC SBD)	$L_\sigma=50nH, T_j=175^\circ C$ FWD <sup>2)</sup> : B3D40065H		142		$\mu J$

2) Note: FWD: Freewheeling diode

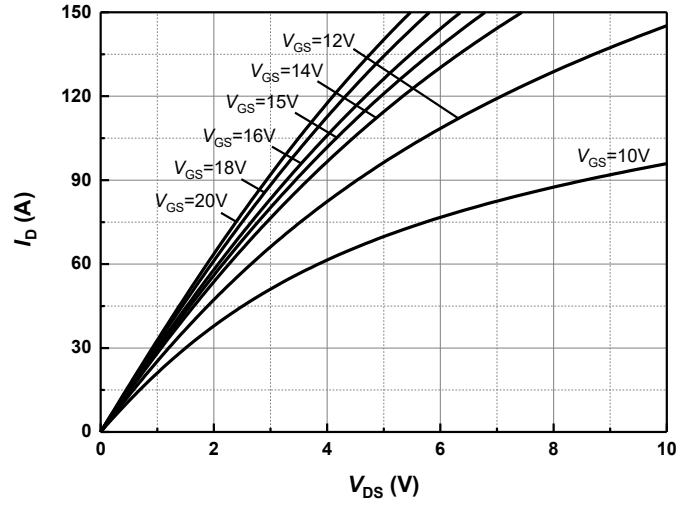
**Reverse Diode Characteristics**

Symbol	Parameter	Test conditions	Value			Unit
			Min.	Typ.	Max.	
$V_{SD}$	Diode Forward Voltage	$V_{GS}=-5V, I_{SD}=25A, T_j=25^{\circ}C$		4.4		V
		$V_{GS}=-5V, I_{SD}=25A, T_j=175^{\circ}C$		3.7		
$I_{SD}$	Continuous Diode Forward Current	$V_{GS}=-5V, T_c=25^{\circ}C$		85		A
$I_{SD,pulse}$	Pulse Diode Current	$V_{GS}=-5V$ , pulse width $t_p$ limited by $T_{jmax}$		160		A
$t_{rr}$	Reverse Recovery Time	$V_{GS}=-5V, V_{DC}=400V, I_{SD}=50A$ $-di_F/dt=1600A/\mu s$ $T_j=25^{\circ}C$		26		ns
$Q_{rr}$	Reverse Recovery Charge			206		nC
$I_{rrm}$	Peak Reverse Recovery Current			12		A
$t_{rr}$	Reverse Recovery Time	$V_{GS}=-5V, V_{DC}=400V, I_{SD}=50A$ $-di_F/dt=1800A/\mu s$ $T_j=175^{\circ}C$		28		ns
$Q_{rr}$	Reverse Recovery Charge			400		nC
$I_{rrm}$	Peak Reverse Recovery Current			20		A

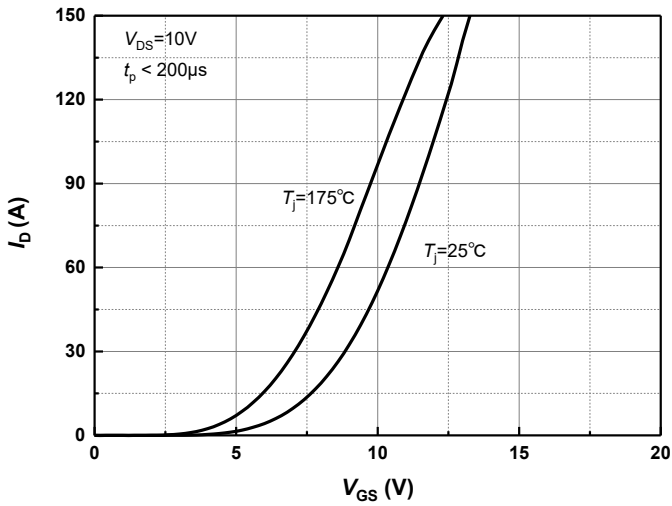
**Typical Performance**



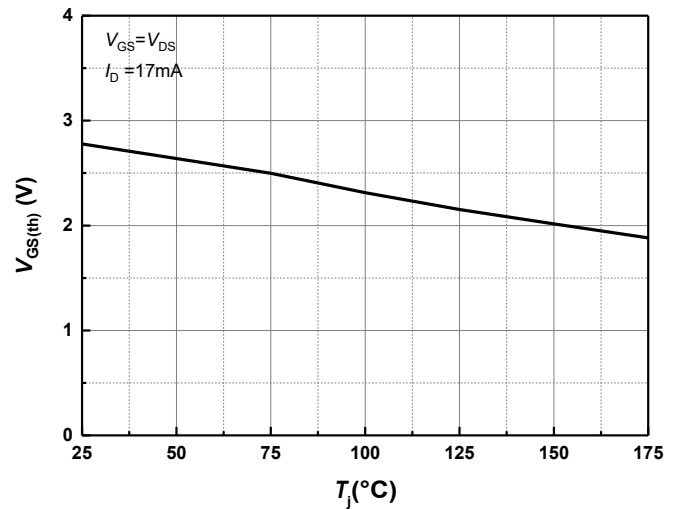
**Figure 1** Typical Forward Output Characteristics at  $T_j = 25^\circ\text{C}$



**Figure 2** Typical Forward Output Characteristics at  $T_j = 175^\circ\text{C}$

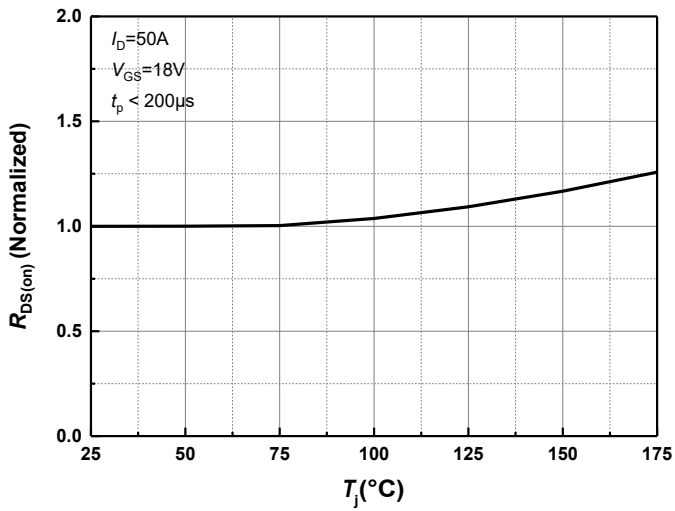


**Figure 3** Transfer Characteristics for Various Temperature

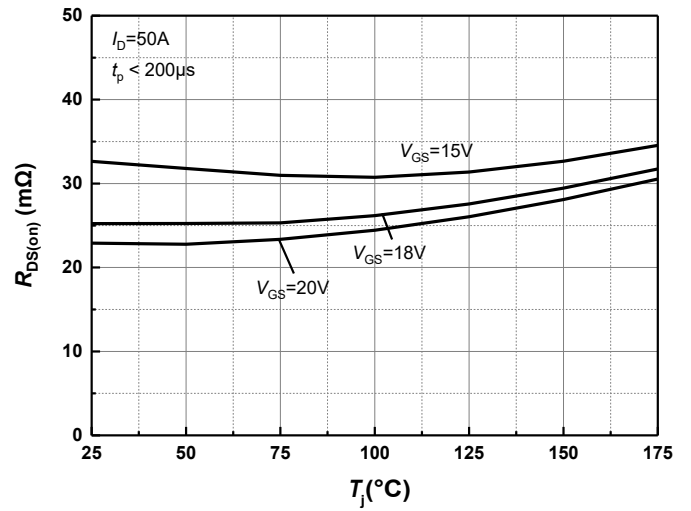


**Figure 4** Threshold Voltage for Various Temperature

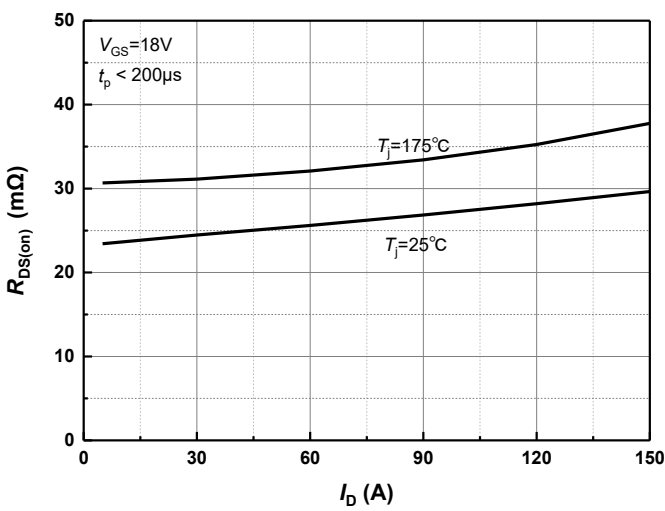
**Typical Performance**



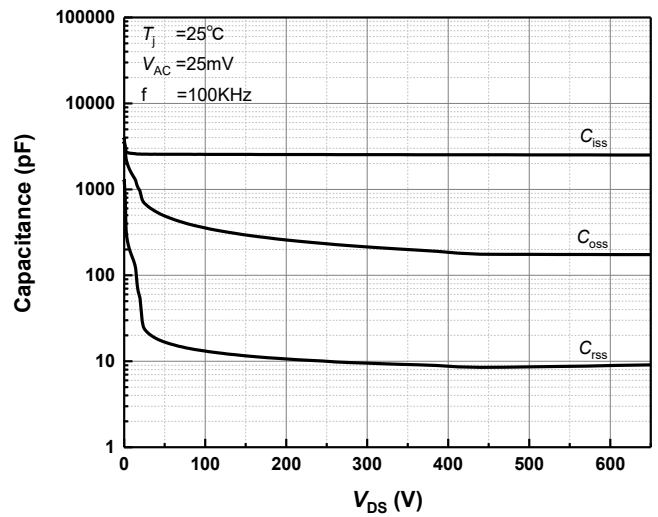
**Figure 5** Normalized On-Resistance for Various Temperature



**Figure 6** On-Resistance vs. Temperature for Various Gate-Source Voltage

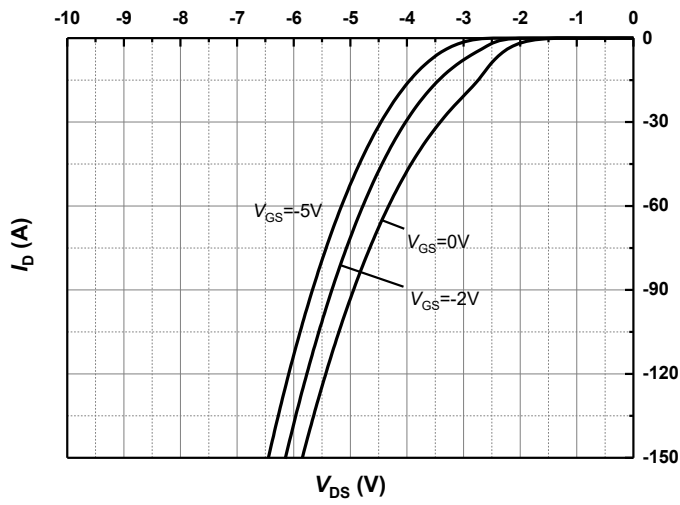


**Figure 7** On-Resistance vs. Drain Current for Various Temperature

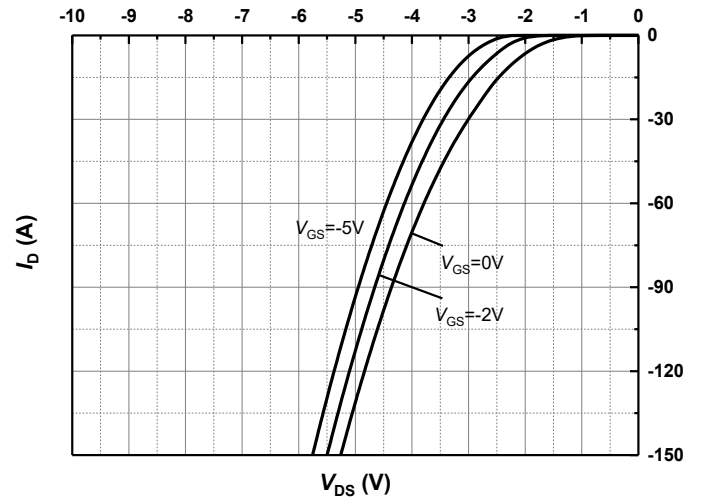


**Figure 8** Capacitance vs. Drain-Source Voltage (0 - 650V)

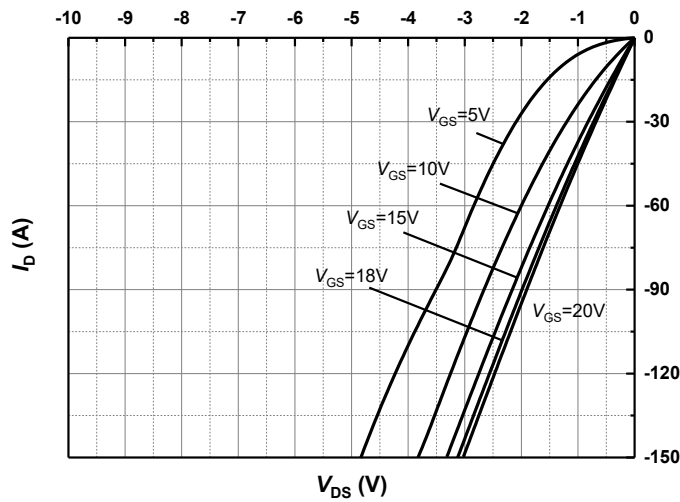
**Typical Performance**



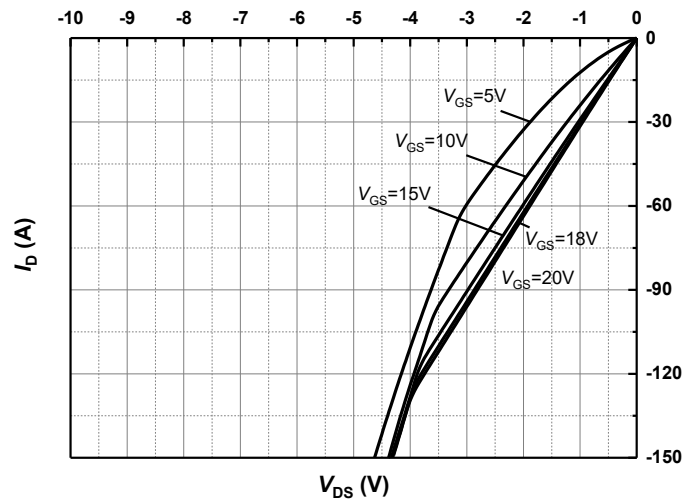
**Figure 9** Body Diode Characteristics at  $T_j=25^\circ\text{C}$



**Figure 10** Body Diode Characteristics at  $T_j=175^\circ\text{C}$

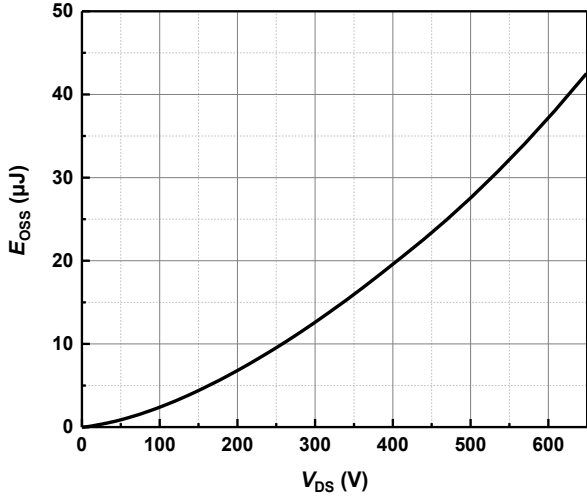


**Figure 11** 3rd Quadrant Characteristics at  $T_j=25^\circ\text{C}$

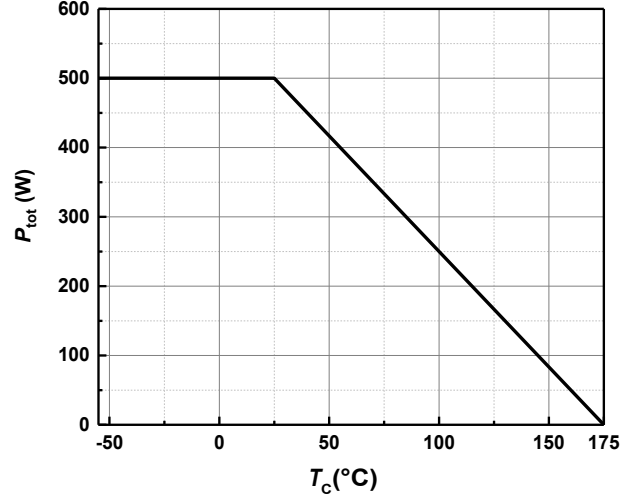


**Figure 12** 3rd Quadrant Characteristics at  $T_j=175^\circ\text{C}$

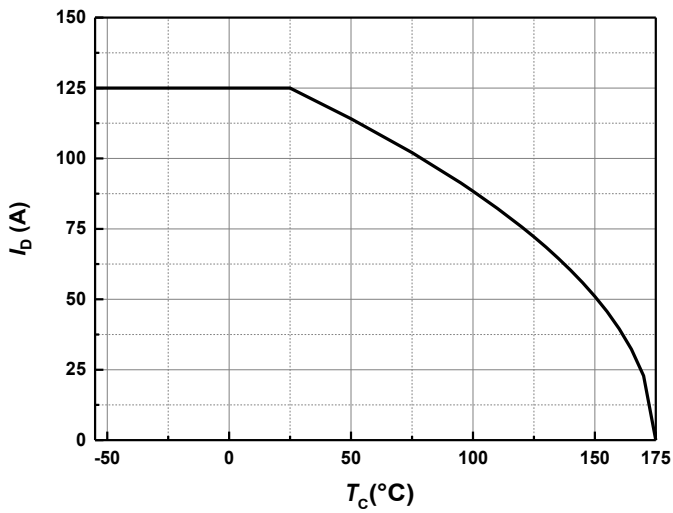
**Typical Performance**



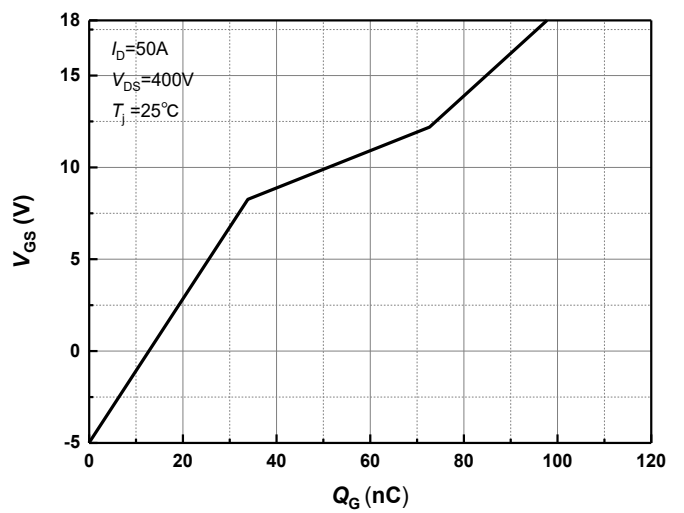
**Figure 13 Output Capacitor stored Energy**



**Figure 14 Maximum Power Dissipation Derating vs. Case Temperature**

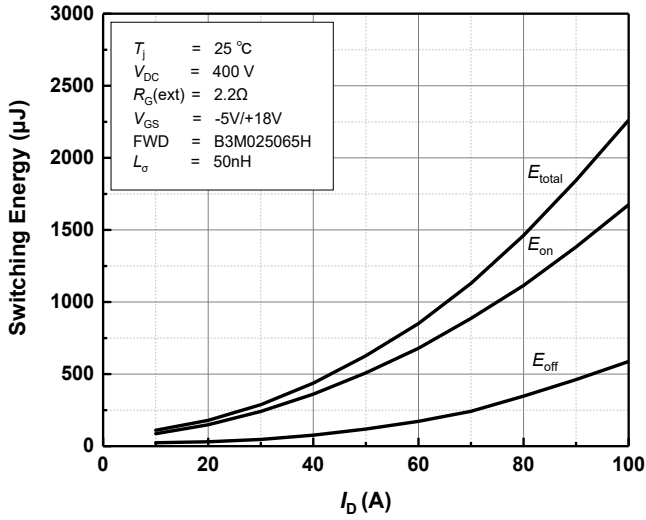


**Figure 15 Continuous Drain Current Derating vs. Case Temperature**

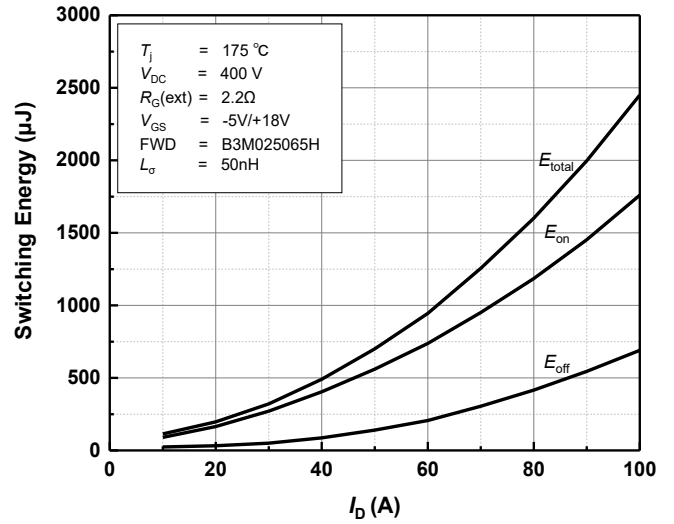


**Figure 16 Gate Charge Characteristics**

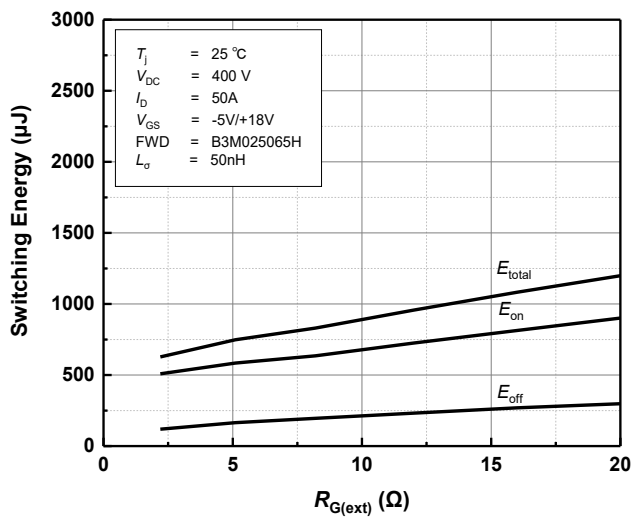
**Typical Performance**



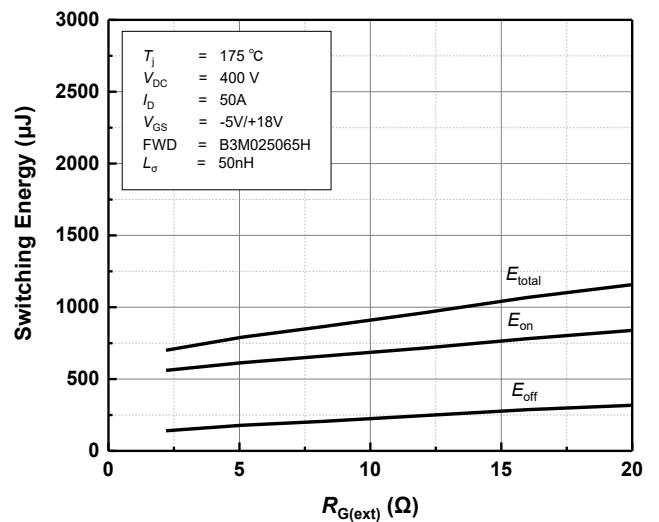
**Figure 17 Clamped Inductive Switching Energy vs. Drain Current ( $V_{DC}=400\text{V}$ ) at  $T_j=25^\circ\text{C}$**



**Figure 18 Clamped Inductive Switching Energy vs. Drain Current ( $V_{DC}=400\text{V}$ ) at  $T_j=175^\circ\text{C}$**

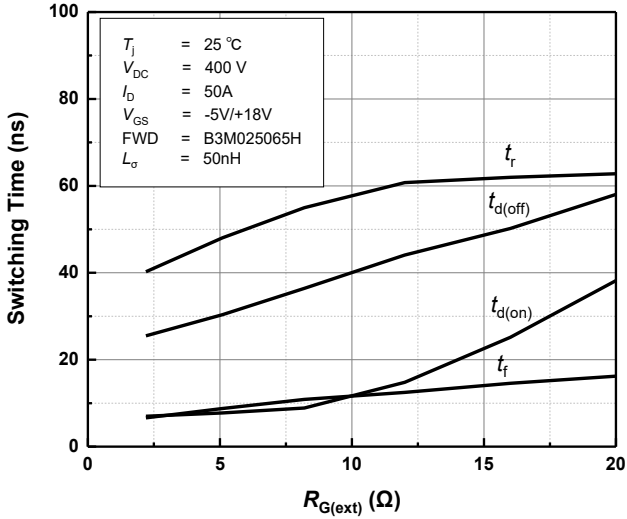


**Figure 19 Clamped Inductive Switching Energy vs. External Gate Resistance at  $T_j=25^\circ\text{C}$**

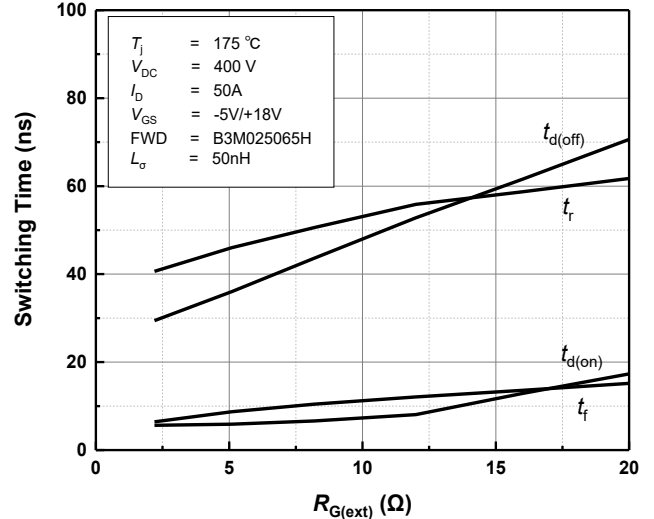


**Figure 20 Clamped Inductive Switching Energy vs. External Gate Resistance at  $T_j=175^\circ\text{C}$**

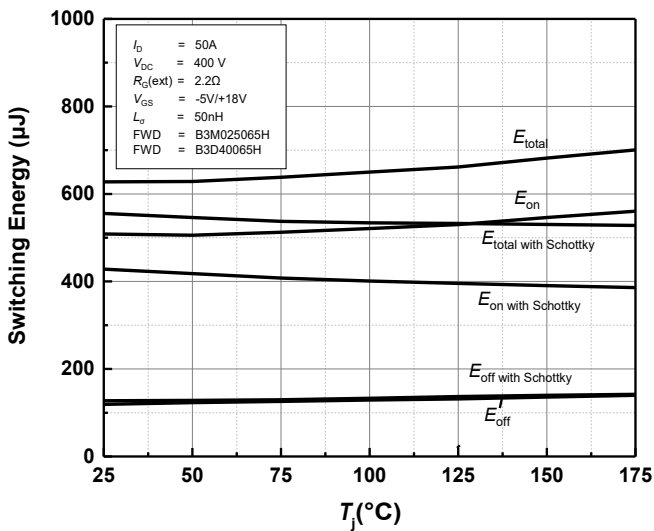
**Typical Performance**



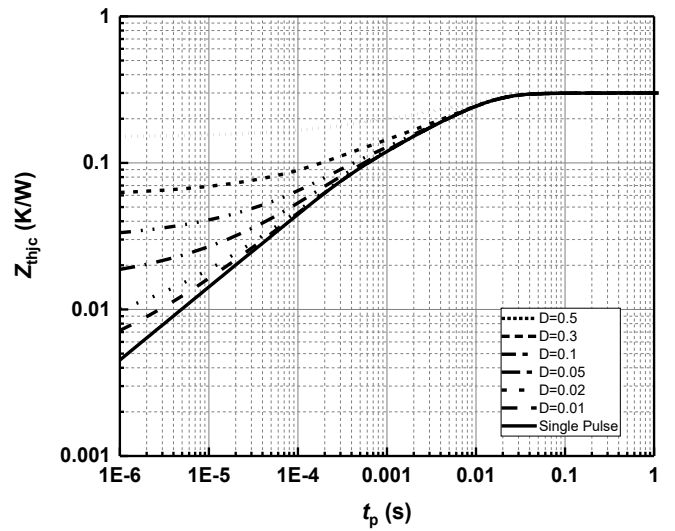
**Figure 21 Clamped Inductive Switching Time vs. External Gate Resistance at  $T_j=25^\circ\text{C}$**



**Figure 22 Clamped Inductive Switching Time vs. External Gate Resistance at  $T_j=175^\circ\text{C}$**

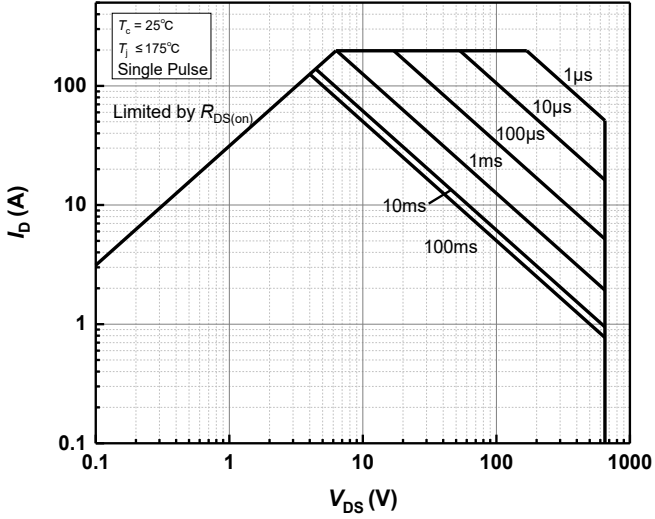


**Figure 23 Clamped Inductive Switching Energy vs. Temperature**

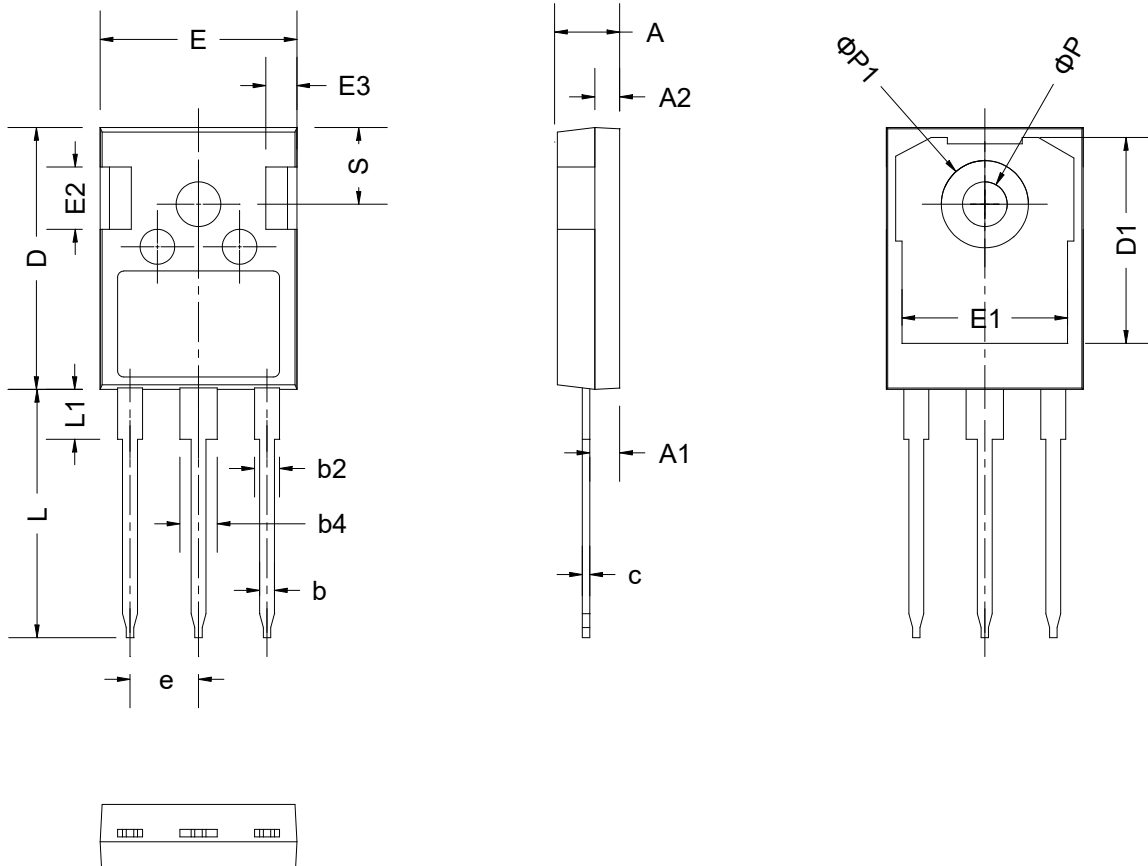


**Figure 24 Transient Thermal Impedance (Junction - Case)**

**Typical Performance**



**Figure 25 Forward Biased Safe Operating Area**

**Package Dimensions**


SYMBOL	mm		
	MIN	NOM	MAX
A	4.80	5.00	5.20
A1	2.21	2.41	2.59
A2	1.85	2.00	2.15
b	1.11	1.21	1.36
b2	1.91	2.01	2.21
b4	2.91	3.01	3.21
c	0.51	0.61	0.75
D	20.80	21.00	21.30
D1	16.25	16.55	16.85
E	15.50	15.80	16.10
E1	13.00	13.30	13.60
E2	4.80	5.00	5.20
E3	2.30	2.50	2.70
e	5.34	5.44	5.54
L	19.62	19.92	20.22
L1	-	-	4.30
φ P	3.40	3.60	3.80
φ P1	-	-	7.30
S	6.06	6.16	6.26

**Revision History**

<b>Document Version</b>	<b>Date of Release</b>	<b>Description of Changes</b>
Rev. 0.0	2025-10-16	Draft datasheet created.

**BASiC Semiconductor Co., Ltd.**  
**Shenzhen, China**  
© 2025 BASiC Semiconductor Co., Ltd.  
**All Rights Reserved.**

**Information**

For further information on technology, delivery terms and conditions and prices, please contact the nearest BASiC Semiconductor Office.

**Disclaimer**

The information given in this document shall in no event be regarded as a guarantee of conditions or characteristics. With respect to any examples or hints given herein, any typical values stated herein and / or any information regarding the application of the device, BASiC Semiconductor Co., Ltd. hereby disclaims any and all warranties and liabilities of any kind, including without limitation, warranties of non-infringement of intellectual property rights of any third party.