

Root cause : The design of V_{REXT} for SCT2168(A) is 1.24V, and is 0.62V for SCT2168(B). So when the voltage amplitude of analog LED dimming signal $I_{AN} > 0.62V$, all $I_{OUT}=0$, and caused the LED matrix did not work.

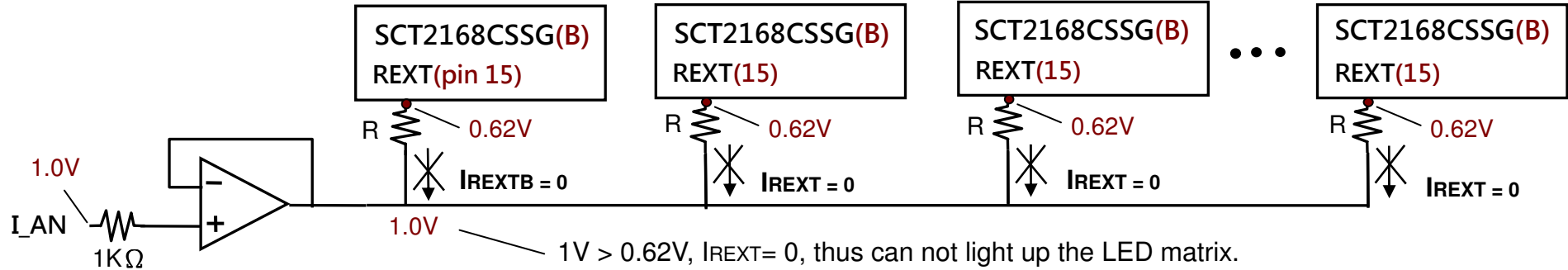

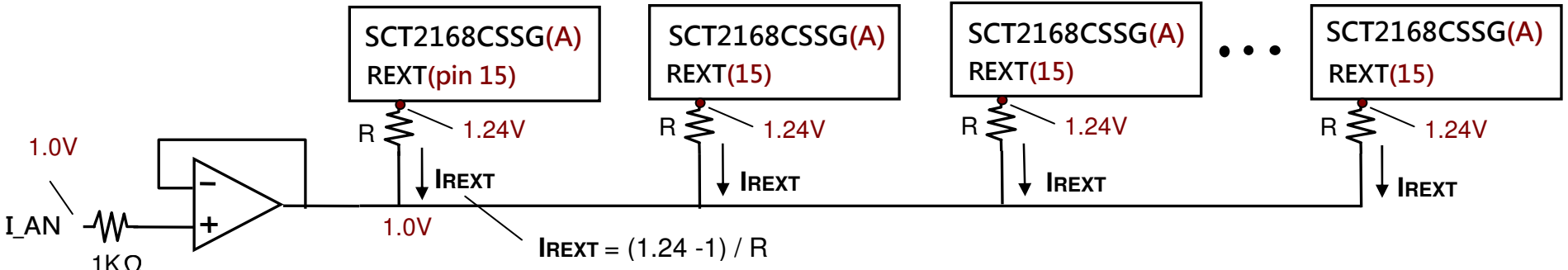
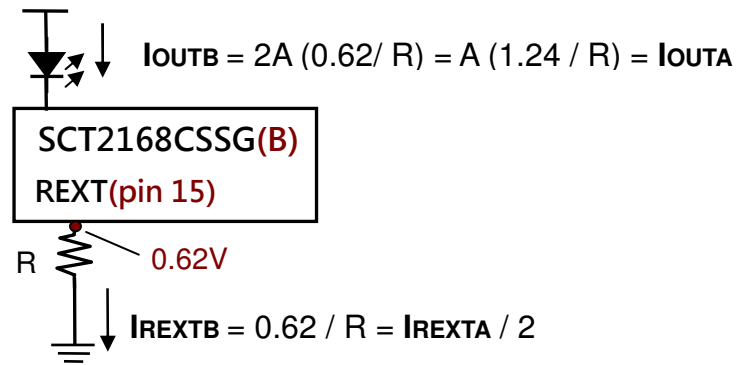
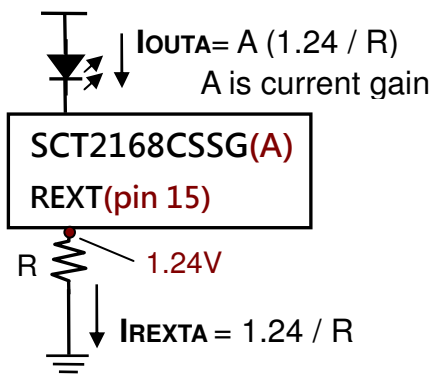

When $I_{REXTA} = 2 I_{REXTB}$, $I_{OUTA} = I_{OUTB}$

So, in application of analog global dimming, there are two ways to get correct LED current.

One is change the I_{AN} amplitude from 1 to 1/2, the another is divide the I_{AN} signal by resistor ladder as the following figure.

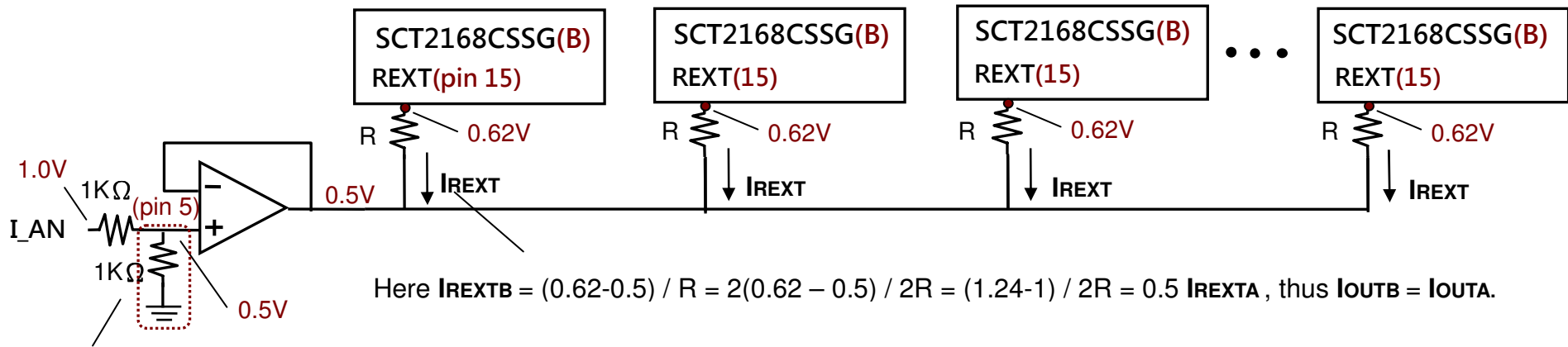

Here $I_{REXTB} = (0.62 - 0.5) / R = 2(0.62 - 0.5) / 2R = (1.24 - 1) / 2R = 0.5 I_{REXTA}$, thus $I_{OUTB} = I_{OUTA}$.

The R-R resistor ladder

The performance of SCT2168(B) is excellent when the IC power voltage is lower than 4V, and VCC=3.3V is strongly recommended. Also, the SCT2168(B) is design to work well in applications without taking care of power sequential. Therefore, in application of SCT2168(B) the 3.3V VCC power can directly come from the same LED power at the same time and thus simple the PCB design. There two ways to do this, one is select the 3.3V power from power board, another is connecting a diode from VLED to VCC as follow.

