

Recommended PCB Layout

(Viewed from Component Side - Tolerance:±0.05mm)

▨ Solder Area □ Component Outline

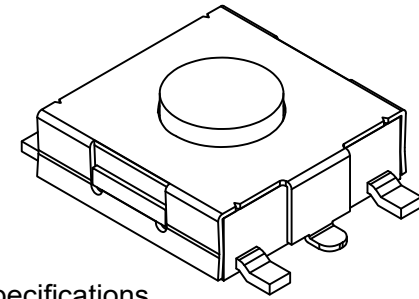

Specifications

Material

Housing: PA9T, UL 94V-0, Black
 Button: PA9T, UL 94V-0, Black
 Terminal: Brass
 Contact: Stainless Steel
 Cover: Phosphor Bronze

Plating

Terminal: Silver Plated
 Contact: Silver Plated
 Cover: Tin Plated

Electrical

Voltage Rating: 12V DC
 Current Rating: 50mA
 Contact Resistance: 100mΩ Max.
 Dielectric Withstanding Voltage: 250V AC
 Insulation Resistance: 100MΩ Min

Mechanical & Environmental

Operating Temperature: -25°C to +85°C
 Operating Force: 160±50gf
 Travel: 0.25±0.10mm
 Durability: 100,000 cycles
 Solder Tails Co-planarity: 0.10mm Max.

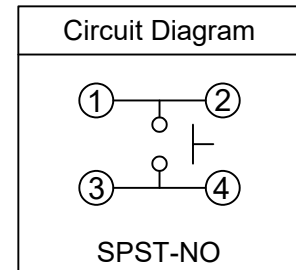
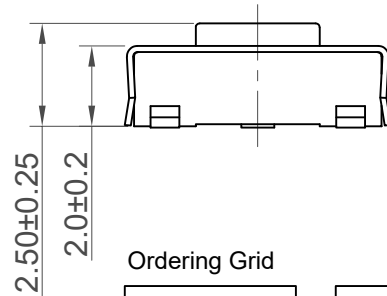
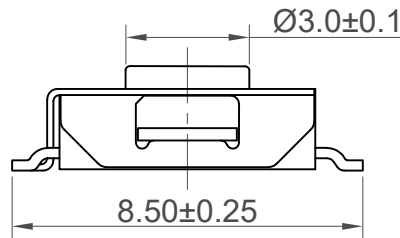

Ordering Grid

SWT0410 - 0250 16 G S A

Request Samples and Quotation

Profile Height
0250 = 2.50mm

Operating Force
16 = 160±50gf

Lead Type
G = Gull wing

Packing Options
A = Tape & Reel
(1500pcs per reel)

Contact Plating
S = Silver

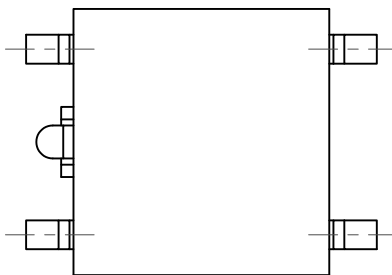

Part Number SWT0410		Product Description Tactile Switch, 6.2 x 6.45mm, Top Actuated, Gull Wing, SPST- NO	
Drawing Date 17th July 2025			
By KY	Detail Drawing Release	Tolerances (Except as Noted) Length X.X ± 0.25 X.XX ± 0.10	Units: Metric (mm)
Revision A	Date 17/07/25	Angle -	3rd Angle Projection
		This drawing is confidential and copyright of Global Connector Technology, Ltd (GCT). This drawing must not be copied or disclosed without written consent. E & OE	
Not to Scale	Drawn By KY	Sheet No. 1/2	



www.gct.co

H
G
F
E
D
C
B
A

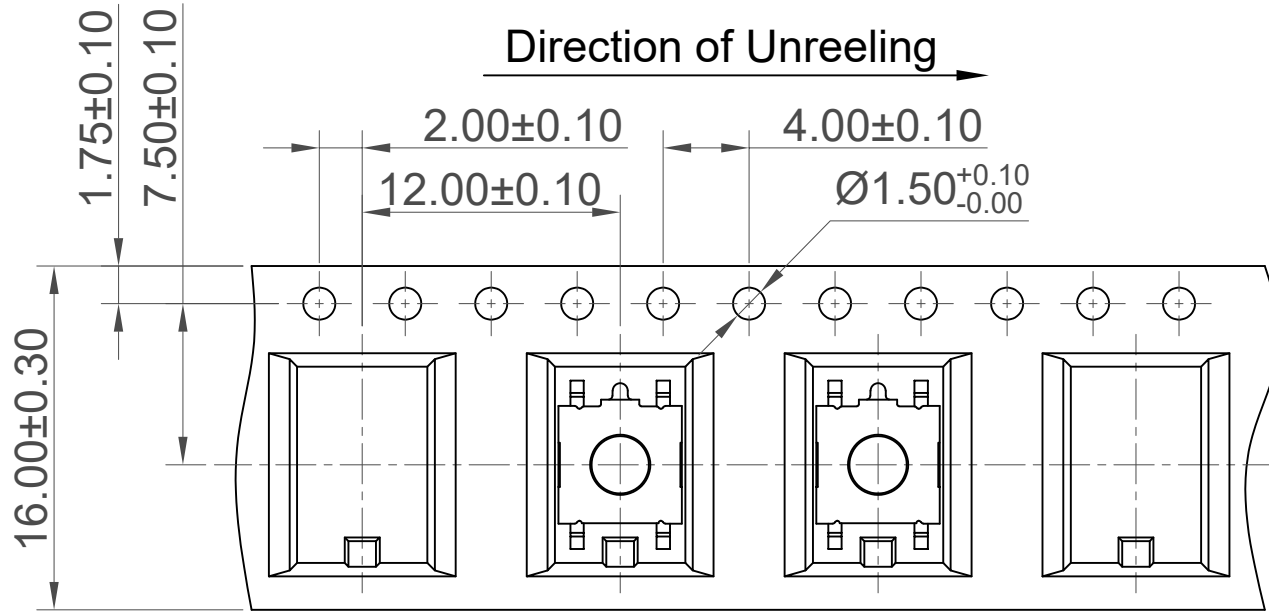
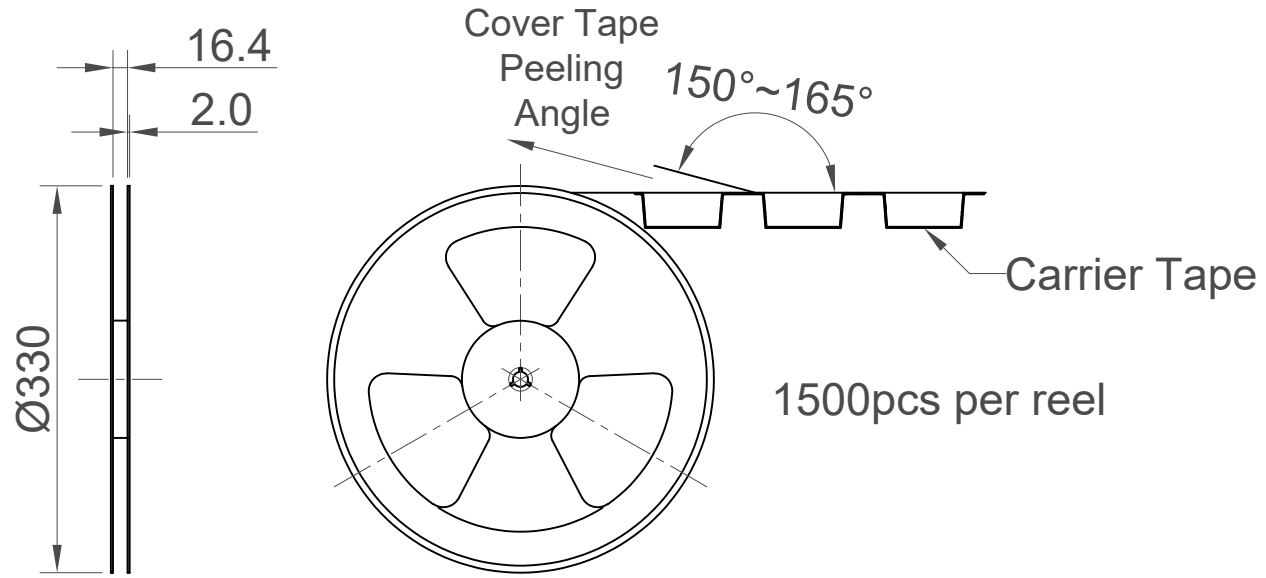

Part Number		Product Description	
SWT0410		Tactile Switch, 6.2 x 6.45mm, Top Actuated, Gull Wing, SPST- NO	
Drawing Date		17th July 2025	
By	KY	Tolerances (Except as Noted)	Units:
Detail	Drawing Release	Length	Metric (mm)
Revision	A	Angle	
Date	17/07/25		

RoHS COMPLIANT
 2011/65/EU
 Deca-SIDE

© This drawing is confidential and copyright of Global Connector Technology, Ltd (GCT). This drawing must not be copied or disclosed without written consent. E & OE

Not to Scale	Drawn By KY	Sheet No. 2/2
--------------	----------------	------------------



www.gct.co