

**Product Summary**

$V_{DS}$	<b>650 V</b>
$I_D (T_C=25^\circ\text{C})$	<b>67 A</b>
$R_{DS(on),typ}$	<b>40 mΩ@<math>V_{GS}=18\text{V}</math></b>

**Features**

- Low On-Resistance with High Blocking Voltage
- Low Capacitance
- Avalanche Ruggedness
- Halogen Free, RoHS Compliant

**Benefits**

- High Frequency Operation
- Enabling Higher Switching Frequency
- Increased Power Density
- Reduction of Heat Sink Requirements

**Applications**

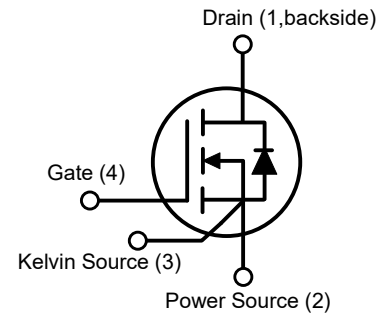
- Switch Mode Power Supplies (SMPS)
- Power Inverter & Solar Inverter
- Motor Drivers & EV Charging Station
- DC/DC Converter

**Package Pin Definitions**

- Pin1 and backside - Drain
- Pin2 - Power Source
- Pin3 - Kelvin Source
- Pin4 - Gate

**Package Parameters**

Part Number	Marking	Package
B3M040065Z	B3M040065Z	TO-247-4

**Package: TO-247-4**


**Maximum Ratings**

Symbol	Parameter	Test conditions	Value	Unit
$V_{DSmax}$	Drain-Source Voltage	$V_{GS}=0V, I_D=100\mu A$	650	V
$V_{GSmax}$	Gate-Source Voltage		-10/22	V
$V_{GSop}$	Recommended Gate-Source Voltage		-4/18	V
$I_D$	Continuous Drain Current	$V_{GS}=18V, T_C=25^\circ C$	67	A
		$V_{GS}=18V, T_C=100^\circ C$	47	A
$I_{D,pulse}$	Pulsed Drain Current	Pulse with $t_p$ limited by $T_{jmax}$	108	A
$P_{tot}$	Power Dissipation	$T_C=25^\circ C, T_j=175^\circ C$	250	W
$T_j$	Operating Junction Temperature		-55~175	$^\circ C$
$T_{stg}$	Storage Temperature		-55~175	$^\circ C$
$M_d$	TO-247 mounting torque	M3 Screw	0.7	N·m

**Electrical Characteristics (Defined at  $T_j=25^\circ C$  unless otherwise specified)**
**Static Characteristics**

Symbol	Parameter	Test conditions	Value			Unit
			Min.	Typ.	Max.	
$V_{(BR)DSS}$	Drain-Source Breakdown Voltage	$V_{GS}=0V, I_D=100\mu A$	650			V
$V_{GS(th)}$	Gate Threshold Voltage	$V_{GS}=V_{DS}, I_D=7.5mA$	2.3	2.7	3.5	V
		$V_{GS}=V_{DS}, I_D=7.5mA, T_j=175^\circ C$		1.9		
$I_{GSS}$	Gate-Source Leakage Current	$V_{GS}=18V, V_{DS}=0V$			100	nA
$I_{DSS}$	Zero Gate Voltage Drain Current	$V_{DS}=650V, V_{GS}=0V$		1	50	$\mu A$
		$V_{DS}=650V, V_{GS}=0V, T_j=175^\circ C$		10	200	
$R_{DS(on)}$	Drain-Source On-State Resistance	$V_{GS}=18V, I_D=20A$		40	55	m $\Omega$
		$V_{GS}=18V, I_D=20A, T_j=175^\circ C$		55		
		$V_{GS}=15V, I_D=20A$		50		
$g_{fs}$	Transconductance	$V_{DS}=10V, I_D=20A$		10		S

**Thermal Characteristics**

Symbol	Parameter	Value			Unit
		Min.	Typ.	Max.	
$R_{th(jc)}$	Thermal Resistance from Junction to Case		0.60		K/W

**AC Characteristics**

Symbol	Parameter	Test conditions	Value			Unit
			Min.	Typ.	Max.	
$C_{iss}$	Input Capacitance	$V_{GS}=0V, V_{DS}=400V$ $f=100kHz, V_{AC}=25mV$		1540		pF
$C_{oss}$	Output Capacitance			130		pF
$C_{rss}$	Reverse Transfer Capacitance			7		pF
$E_{oss}$	$C_{oss}$ Stored Energy			12		$\mu J$
$C_{O(ER)}$	Effective Output Capacitance, Energy Related	$V_{GS}=0V, 0V < V_{DS} < 400V$		150		pF
$C_{O(TR)}$	Effective Output Capacitance, Time Related	$V_{GS}=0V, 0V < V_{DS} < 400V$		204		pF
$R_{G(int)}$	Internal Gate Resistance	$f=1MHz, V_{AC}=25mV$		1.4		$\Omega$

**Gate Charge Characteristics**

Symbol	Parameter	Test conditions	Value			Unit
			Min.	Typ.	Max.	
$Q_{GS}$	Gate to Source Charge	$V_{DS}=400V$ $I_D=20A$ $V_{GS}=-4/+18V$		20		nC
$Q_{GD}$	Gate to Drain Charge			24		nC
$Q_G$	Total Gate Charge			60		nC

**Switching Characteristics**

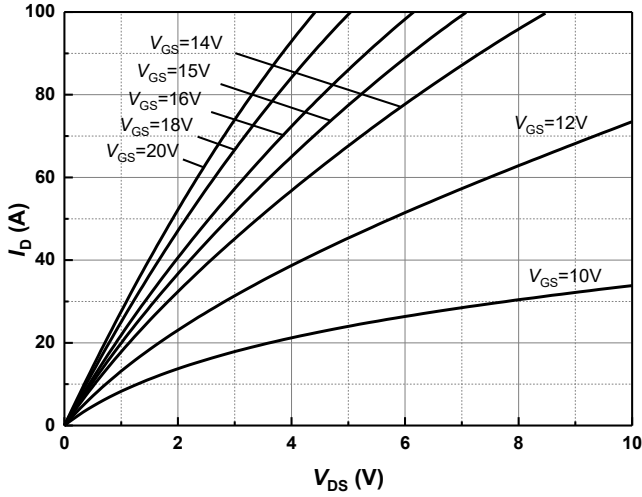
Symbol	Parameter	Test conditions	Value			Unit
			Min.	Typ.	Max.	
$t_{d(on)}$	Turn-On Delay Time			10		ns
$t_r$	Rise Time	$V_{DC}=400V, V_{GS}=-4/18V$ $I_D=20A, R_{G(ext)}=10\Omega$		20		ns
$t_{d(off)}$	Turn-Off Delay Time	$L_\sigma=50nH, T_j=25^\circ C$ FWD <sup>1)</sup> : body diode at $V_{GS}=-4V$		31		ns
$t_f$	Fall Time	Inductive Load Eon includes diode reverse recovery		8		ns
$E_{on}$	Turn-On Energy(FWD=Body Diode)			115		$\mu J$
$E_{off}$	Turn-Off Energy(FWD=Body Diode)			27		$\mu J$
$E_{on}$	Turn-On Energy(FWD=SiC Diode)	$V_{DC}=400V, V_{GS}=-4/18V$ $I_D=20A, R_{G(ext)}=10\Omega$		95		$\mu J$
$E_{off}$	Turn-Off Energy(FWD=SiC Diode)	$L_\sigma=50nH, T_j=25^\circ C$ FWD <sup>1)</sup> : B3D20065H		29		$\mu J$
$t_{d(on)}$	Turn-On Delay Time			7		ns
$t_r$	Rise Time	$V_{DC}=400V, V_{GS}=-4/18V$ $I_D=20A, R_{G(ext)}=10\Omega$		18		ns
$t_{d(off)}$	Turn-Off Delay Time	$L_\sigma=50nH, T_j=175^\circ C$ FWD <sup>1)</sup> : body diode at $V_{GS}=-4V$		37		ns
$t_f$	Fall Time	Inductive Load Eon includes diode reverse recovery		7		ns
$E_{on}$	Turn-On Energy(FWD=Body Diode)			120		$\mu J$
$E_{off}$	Turn-Off Energy(FWD=Body Diode)			27		$\mu J$
$E_{on}$	Turn-On Energy(FWD=SiC Diode)	$V_{DC}=400V, V_{GS}=-4/18V$ $I_D=20A, R_{G(ext)}=10\Omega$		78		$\mu J$
$E_{off}$	Turn-Off Energy(FWD=SiC Diode)	$L_\sigma=50nH, T_j=175^\circ C$ FWD <sup>1)</sup> : B3D20065H		29		$\mu J$

1) Note: FWD: Freewheeling diode

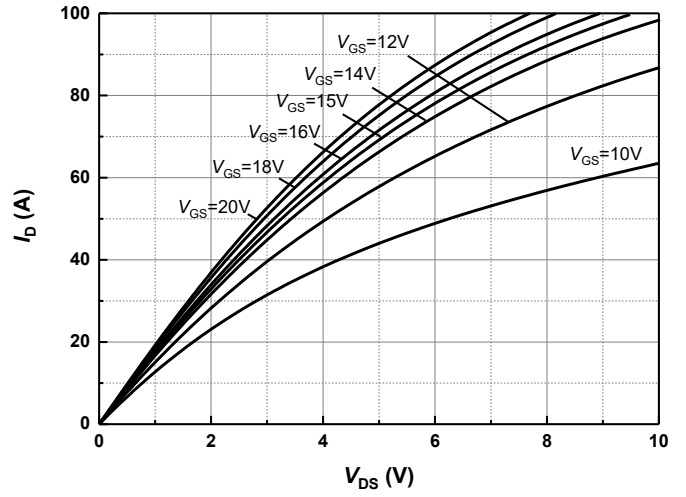
**Reverse Diode Characteristics**

Symbol	Parameter	Test conditions	Value			Unit
			Min.	Typ.	Max.	
$V_{SD}$	Diode Forward Voltage	$V_{GS}=-4V, I_{SD}=10A, T_j=25^{\circ}C$		4.0		V
		$V_{GS}=-4V, I_{SD}=10A, T_j=175^{\circ}C$		3.4		
$I_{SD}$	Continuous Diode Forward Current	$V_{GS}=-4V, T_c=25^{\circ}C$		44		A
$I_{SD,pulse}$	Pulsed Drain Current	$V_{GS}=-4V$ , pulse width $t_p$ limited by $T_{jmax}$		85		A
$t_{rr}$	Reverse Recovery Time	$V_{GS}=-4V, V_{DC}=400V, I_{SD}=20A$ $-di_F/dt=2600A/\mu s$ $T_j=25^{\circ}C$		11		ns
$Q_{rr}$	Reverse Recovery Charge			100		nC
$I_{rrm}$	Peak Reverse Recovery Current			15		A
$t_{rr}$	Reverse Recovery Time	$V_{GS}=-4V, V_{DC}=400V, I_{SD}=20A$ $-di_F/dt=3500A/\mu s$ $T_j=175^{\circ}C$		13		ns
$Q_{rr}$	Reverse Recovery Charge			210		nC
$I_{rrm}$	Peak Reverse Recovery Current			26		A

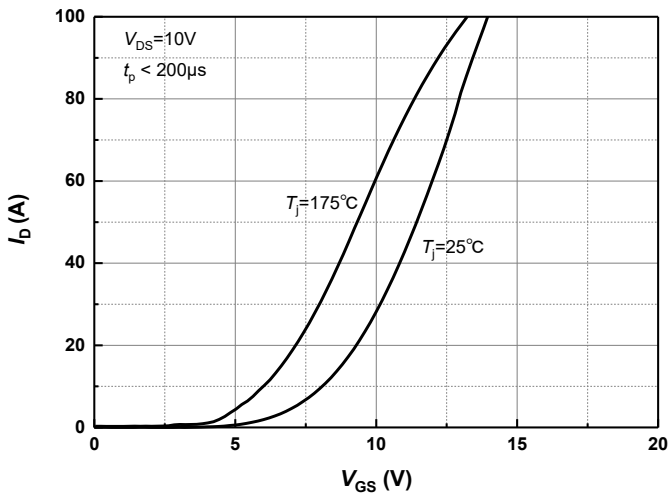
**Typical Performance**



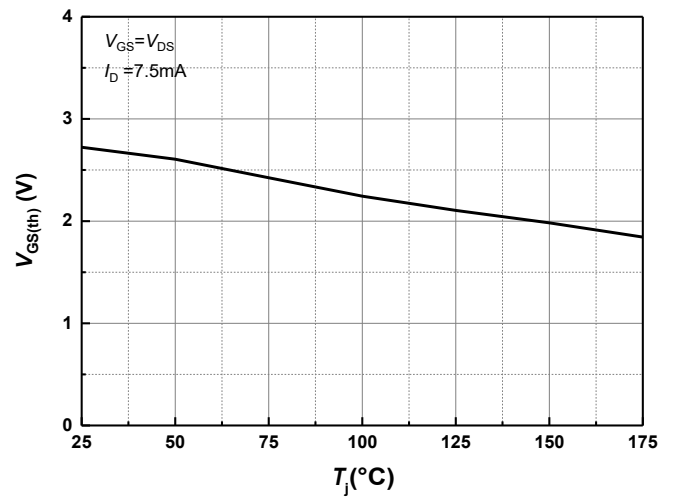
**Figure 1** Typical Forward Output Characteristics at  $T_j = 25^\circ\text{C}$



**Figure 2** Typical Forward Output Characteristics at  $T_j = 175^\circ\text{C}$

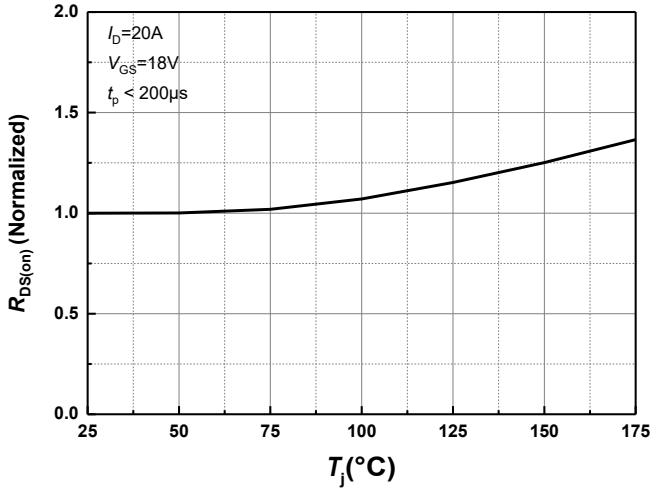


**Figure 3** Transfer Characteristics for Various Temperature

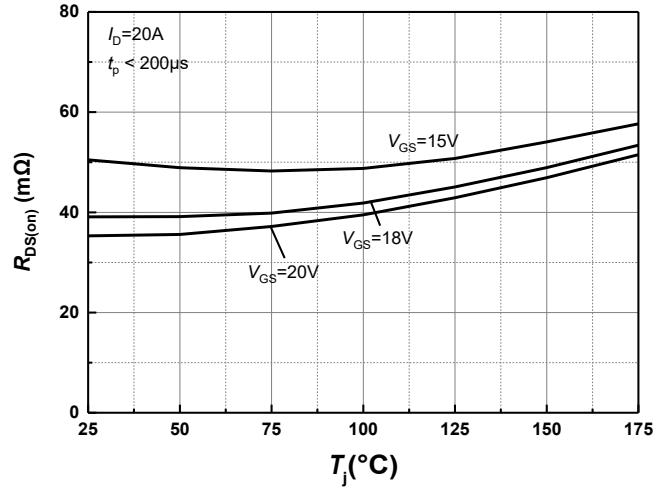


**Figure 4** Threshold Voltage for Various Temperature

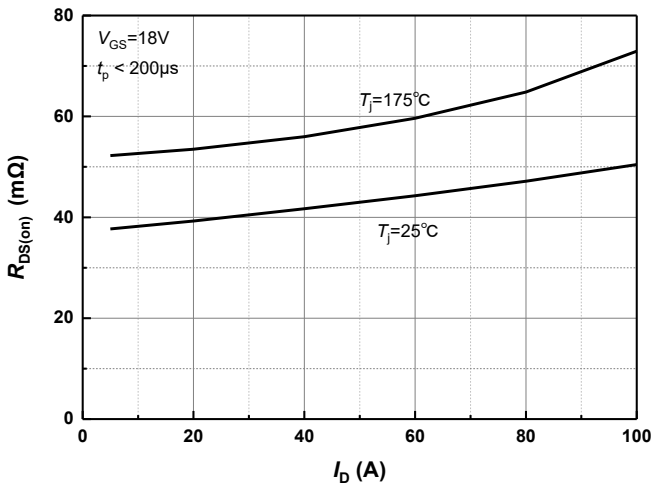
**Typical Performance**



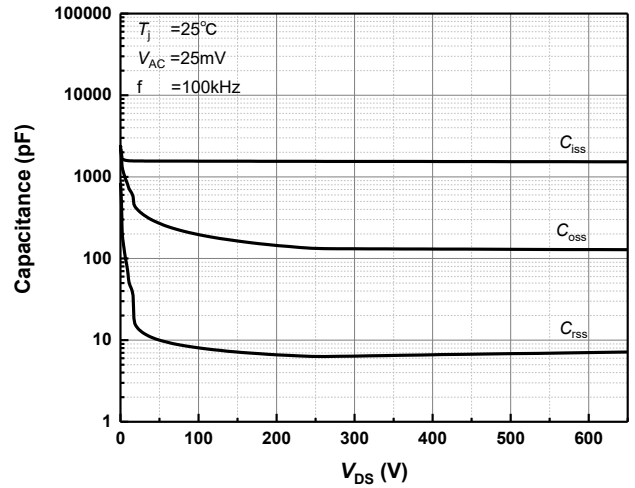
**Figure 5 Normalized On-Resistance for Various Temperature**



**Figure 6 On-Resistance vs. Temperature for Various Gate-Source Voltage**

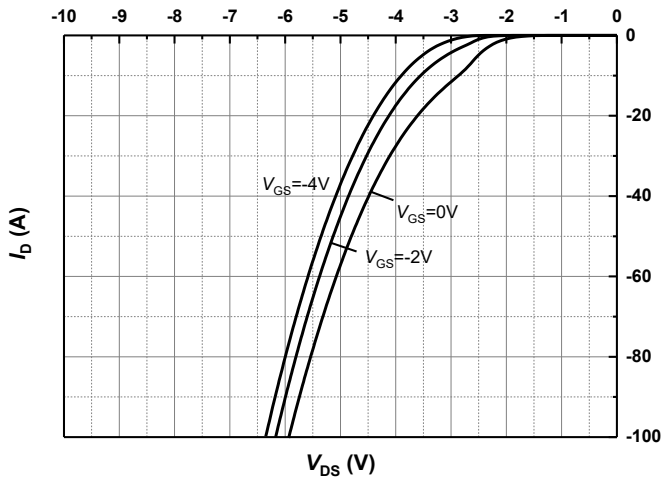


**Figure 7 On-Resistance vs. Drain Current for Various Temperature**

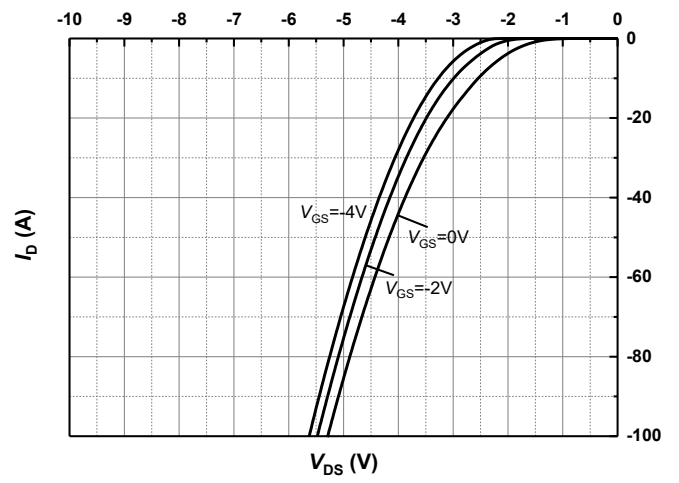


**Figure 8 Capacitance vs. Drain-Source Voltage (0 - 650V)**

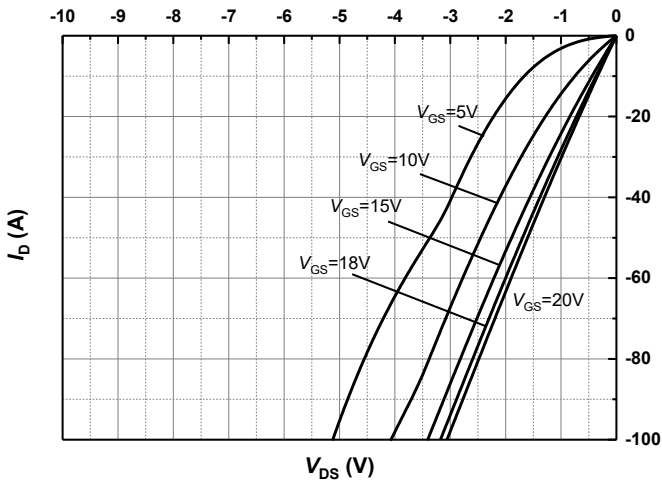
**Typical Performance**



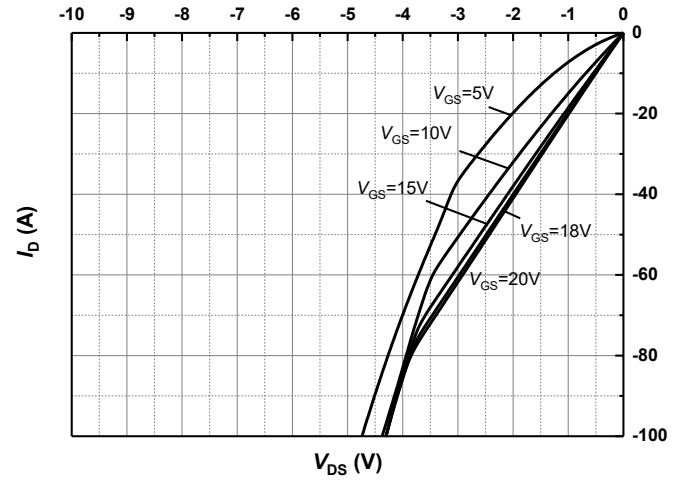
**Figure 9** Body Diode Characteristics at  $T_j=25^\circ\text{C}$



**Figure 10** Body Diode Characteristics at  $T_j=175^\circ\text{C}$

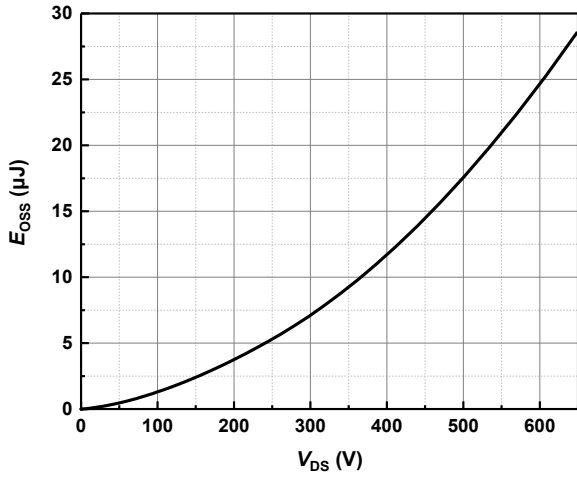


**Figure 11** 3rd Quadrant Characteristics at  $T_j=25^\circ\text{C}$

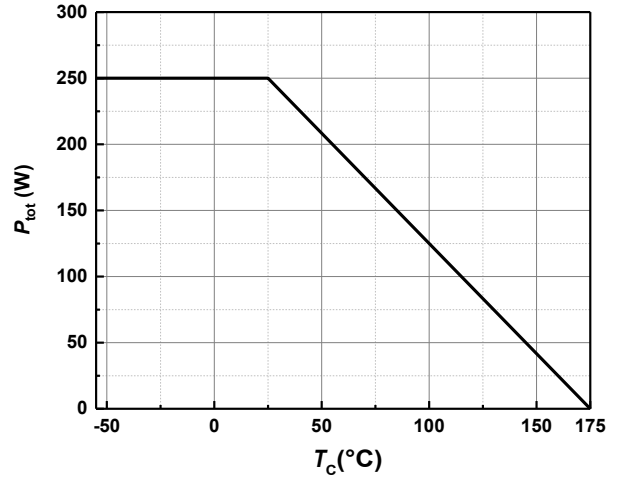


**Figure 12** 3rd Quadrant Characteristics at  $T_j=175^\circ\text{C}$

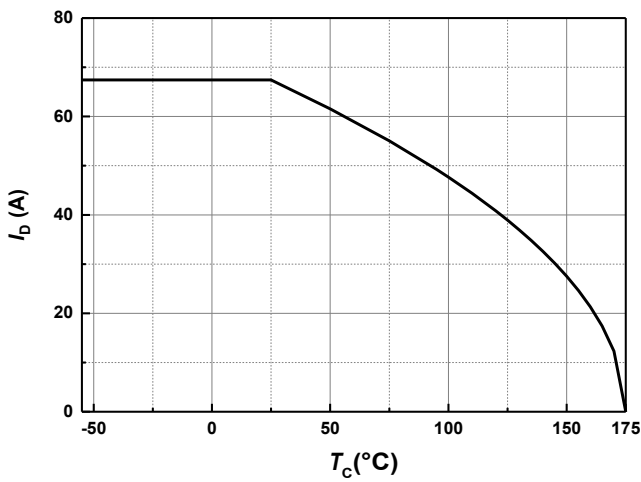
**Typical Performance**



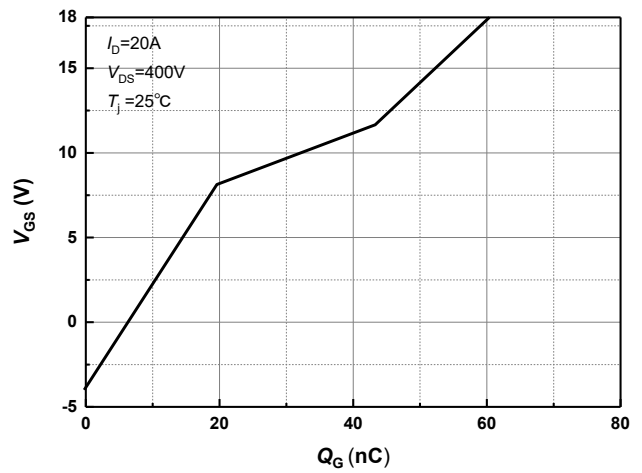
**Figure 13 Output Capacitor stored Energy**



**Figure 14 Maximum Power Dissipation Derating vs. Case Temperature**

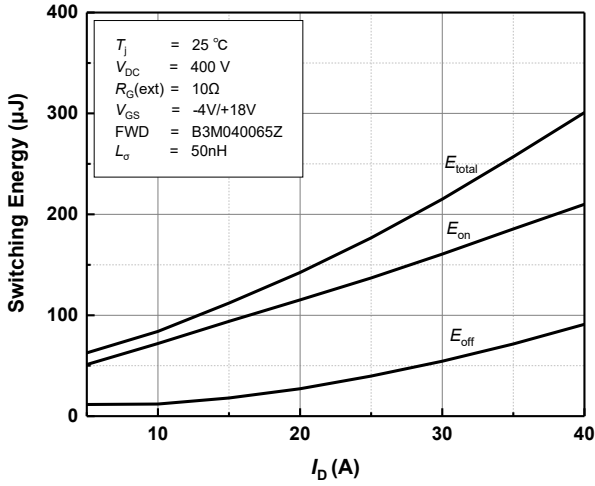


**Figure 15 Continuous Drain Current Derating vs. Case Temperature**

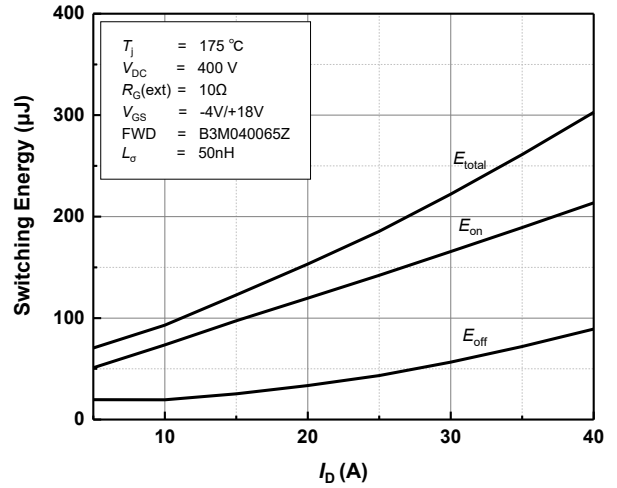


**Figure 16 Gate Charge Characteristics**

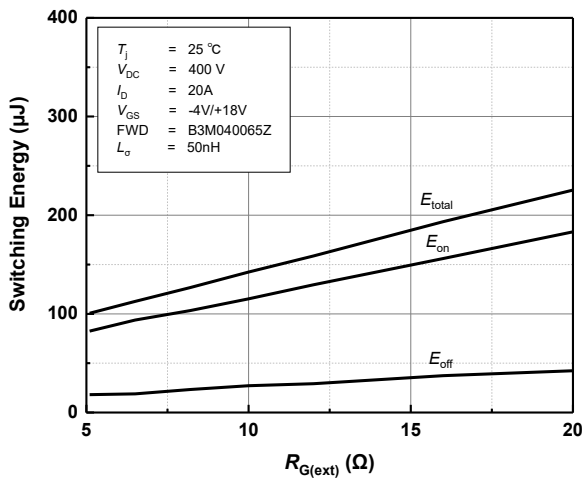
**Typical Performance**



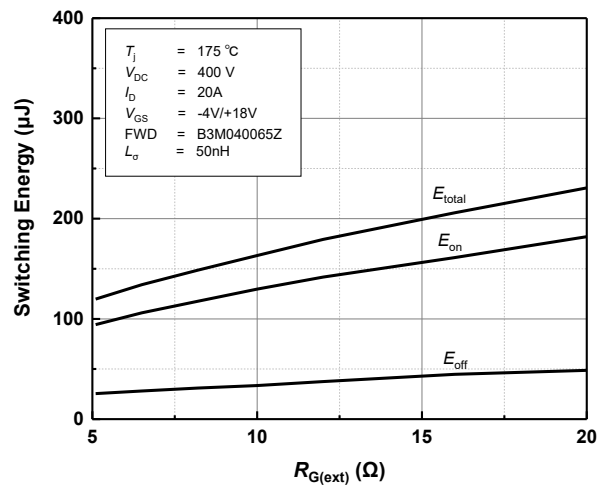
**Figure 17 Clamped Inductive Switching Energy vs. Drain Current ( $V_{\text{DC}} = 400\text{V}$ ) at  $T_j = 25^\circ\text{C}$**



**Figure 18 Clamped Inductive Switching Energy vs. Drain Current ( $V_{\text{DC}} = 400\text{V}$ ) at  $T_j = 175^\circ\text{C}$**

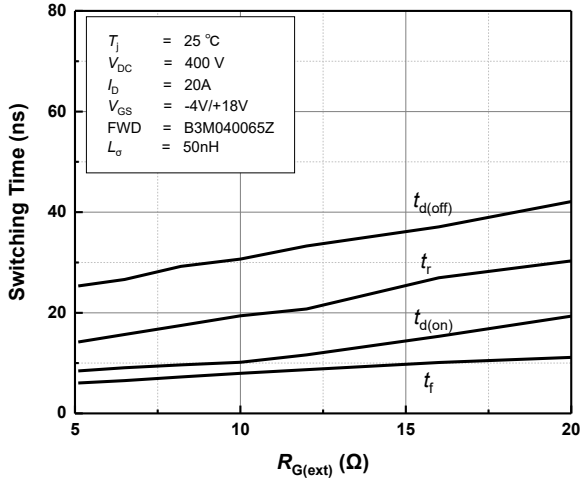


**Figure 19 Clamped Inductive Switching Energy vs. External Gate Resistance at  $T_j = 25^\circ\text{C}$**

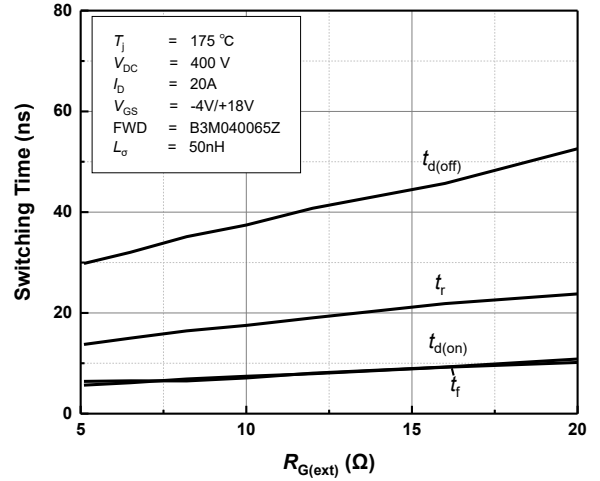


**Figure 20 Clamped Inductive Switching Energy vs. External Gate Resistance at  $T_j = 175^\circ\text{C}$**

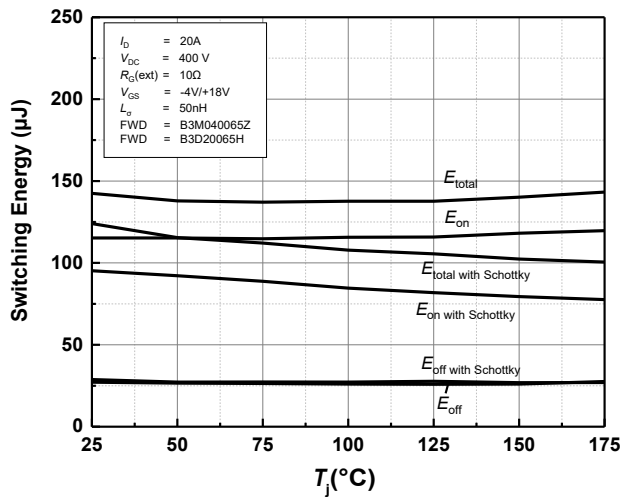
**Typical Performance**



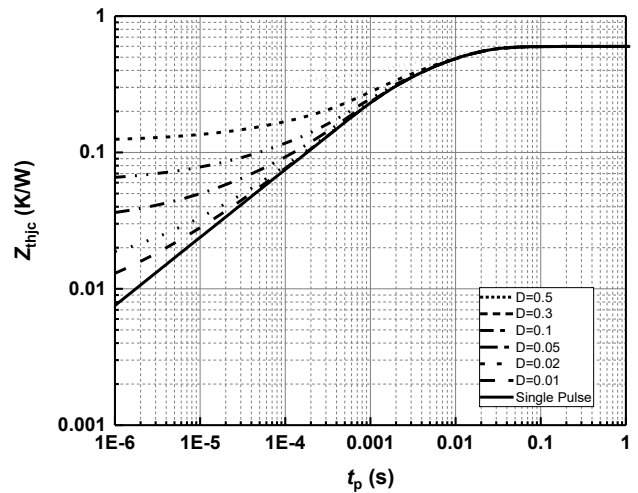
**Figure 21 Clamped Inductive Switching Time vs. External Gate Resistance at  $T_j=25^\circ\text{C}$**



**Figure 22 Clamped Inductive Switching Time vs. External Gate Resistance at  $T_j=175^\circ\text{C}$**

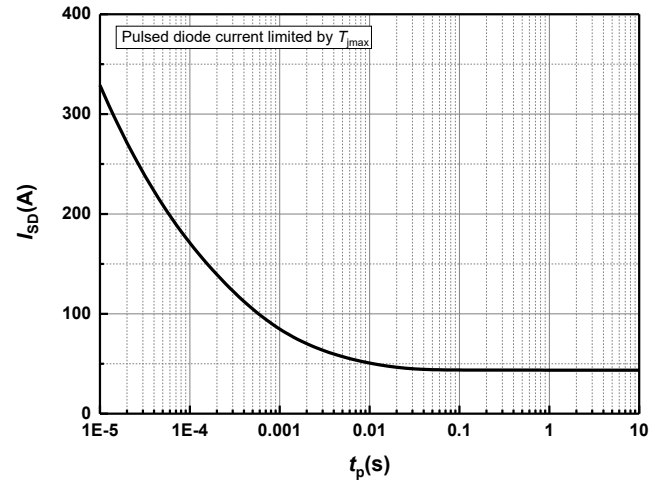
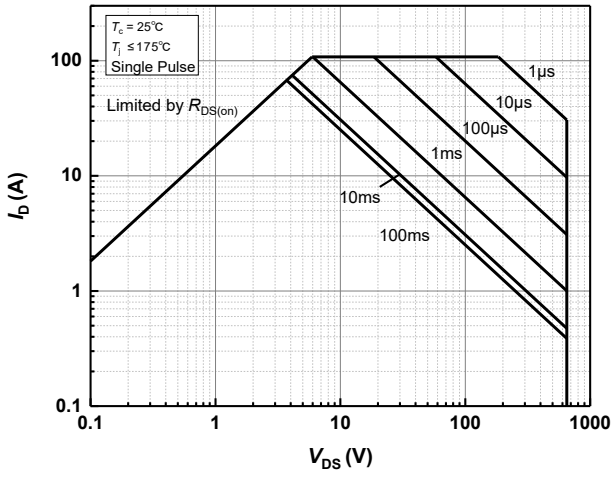


**Figure 23 Clamped Inductive Switching Energy vs. Temperature**



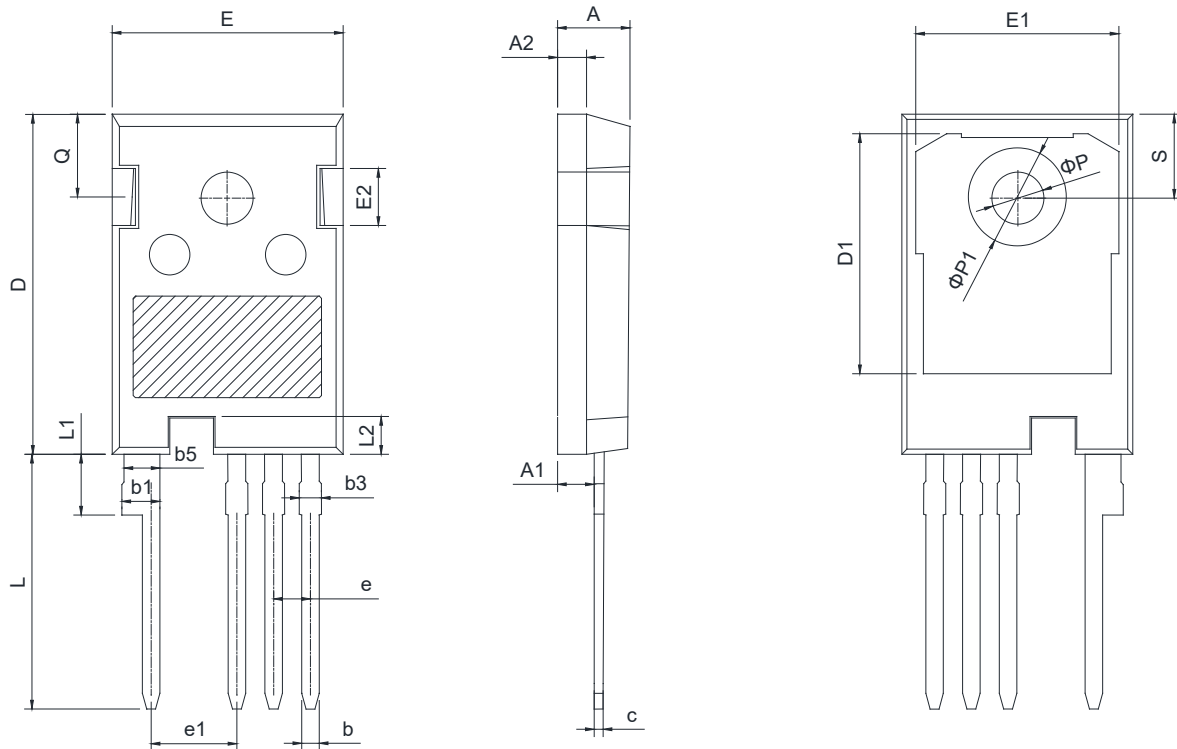
**Figure 24 Transient Thermal Impedance (Junction - Case)**

**Typical Performance**



**Figure 25 Forward Biased Safe Operating Area**

**Figure 26 Pulsed Diode Current vs. Pulse width**

**Package Dimensions**


SYMBOL	mm		
	MIN	NOM	MAX
A	4.80	5.00	5.21
A1	2.21	2.41	2.61
A2	1.80	2.00	2.20
b	1.06	1.21	1.36
b1	2.33	2.63	2.93
b3	1.07	1.30	1.60
b5	2.30	2.53	2.72
c	0.51	0.61	0.75
D	23.30	23.45	23.60
D1	16.25	16.55	17.65
E	15.74	15.94	16.14
E1	13.72	14.02	14.32
E2	3.68	4.40	5.10
e	2.44	2.54	2.64
e1	4.98	5.08	5.18
L	17.27	17.57	17.87
L1	3.97	4.19	4.39
L2	2.35	2.50	2.65
$\phi p$	3.40	3.60	3.80
$\phi p1$	7.19REF		
Q	5.49	5.79	6.09
S	6.00	6.17	6.40

REF: For reference only, no measurement is required.

**Revision History**

<b>Document Version</b>	<b>Date of Release</b>	<b>Description of Changes</b>
Rev. 0.0	2025-01-10	Draft datasheet created.
Rev. 0.1	2025-11-11	Add Fig 26.
Rev. 0.2	2025-12-06	Update.

**BASiC Semiconductor Co., Ltd.**  
**Shenzhen, China**  
© 2025 BASiC Semiconductor Co., Ltd.  
**All Rights Reserved.**

**Information**

For further information on technology, delivery terms and conditions and prices, please contact the nearest BASiC Semiconductor Office.

**Disclaimer**

The information given in this document shall in no event be regarded as a guarantee of conditions or characteristics. With respect to any examples or hints given herein, any typical values stated herein and / or any information regarding the application of the device, BASiC Semiconductor Co., Ltd. hereby disclaims any and all warranties and liabilities of any kind, including without limitation, warranties of non-infringement of intellectual property rights of any third party.