

1 2 3 4 5 6 7

FOR 客户名称	APPROVED 客户确认签字	ATTN 销售负责人

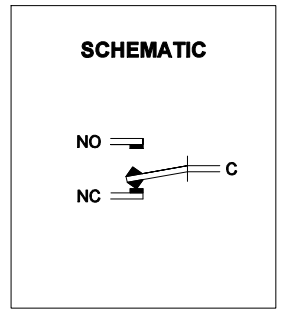
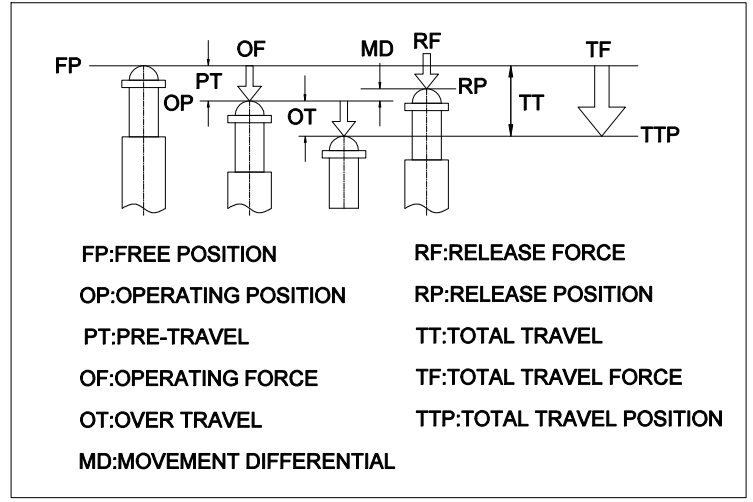
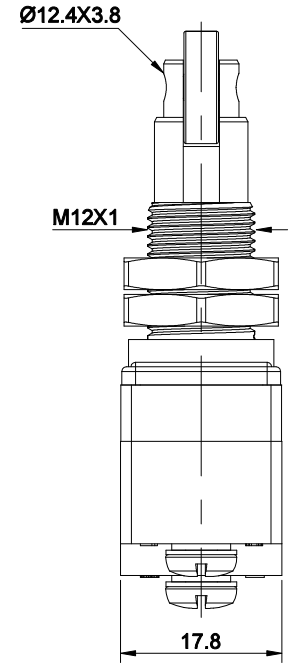
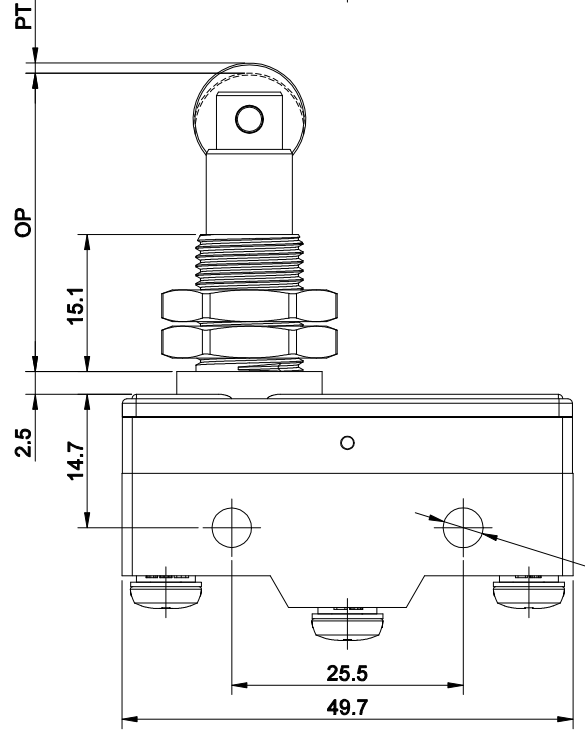
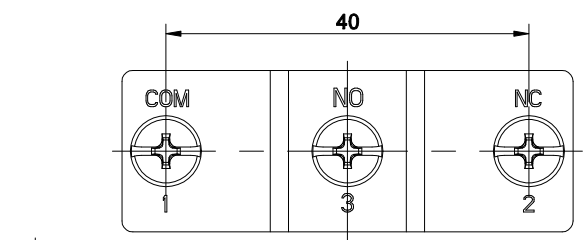

TYPE	LTM-1309
OF Max.	350g
RF Min.	114g
PT Max.	0.4mm
OT Min.	3.58mm
MD Max.	0.05mm
FP Max.	
OP	33.4±1.2mm

- SPECIFICATIONS:**
- SWITCH RATING: AC250V/15A, DC250V/0.03A.
  - MECHANICAL LIFE: ≥10,000,000 cycles.
  - ELECTRICAL LIFE: ≥50,000 cycles.
  - CONTACT RESISTANCE: ≤200mΩ.
  - INSULATION RESISTANCE: ≥100MΩ(500VDC).
  - POWER-FREQUENCY WITHSTAND VOLTAGE:  
BETWEEN DISCONTINUOUS TERMINAL: 1,000VAC, 50/60Hz, 1min;  
BETWEEN CURRENT CARRYING PARTS AND NON-CURRENT CARRYING PARTS: 1,500VAC, 50/60Hz, 1min;  
BETWEEN TERMINAL AND GND: 1,500VAC, 50/60Hz, 1min.
  - OPERATING TEMPERATURE: -10°C~ +80°C(NO FREEZING).
  - FRONT PANEL PROTECTION DEGREE: IP40.
  - TERMINAL TYPE: SCREW TERMINAL.
  - GENERAL TOLERANCE: 0-18mm=±0.25, 18-80mm=±0.52.
  - COMPLIANT WITH RoHS.

- MATERIALS:**
- CONTACT: SILVER ALLOY.
  - ROCKER: STAINLESS STEEL.
  - BODY: UF.

PART NUMBER:LTM-1309

BRAND 品牌		红波按钮制造有限公司		
ONPOW 欧宝龙®		ONPOW PUSH BUTTON MANUFACTURE CO.,LTD.		
TITLE 名称	LTM-13 MICRO SWITCH		UNIT 单位	mm
DWG NO. 图号	LTM-1309	SCALE 比例	1.2 : 1	SIZE 图纸
FILE NAME 档案名称	LTM-13.DWG	DRAWN 制图	HCP 2025/04/08	SHEET 张
			1/1	REV. 版本
				V1.0

1 2 3 4 5 6 7