

Product Summary

V_{DS}	650 V
$I_D (T_C=25^\circ\text{C})$	108 A
$R_{DS(on),typ}$	25 mΩ@$V_{GS}=18\text{V}$

Features

- Low On-Resistance with High Blocking Voltage
- Low Capacitance
- Avalanche Ruggedness
- Halogen Free, RoHS Compliant

Benefits

- High Frequency Operation
- Enabling Higher Switching Frequency
- Increased Power Density
- Reduction of Heat Sink Requirements

Applications

- Switch Mode Power Supplies (SMPS)
- Power Inverter & Solar Inverter
- Motor Drivers & EV Charging Station
- DC/DC Converter

Package Pin Definitions

- Pin9-16, topside - Drain
- Pin8 - Gate
- Pin7 - Kelvin Source
- Pin1-6 - Power Source

Package Parameters

Part Number	Marking	Package
B3M025065B	B3M025065B	TOLT

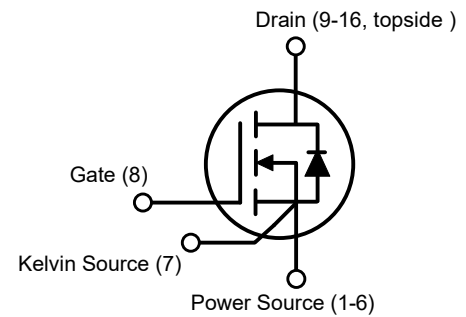
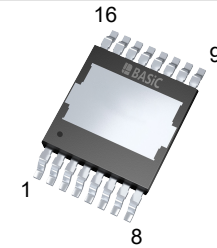
Package: TOLT

Maximum Ratings

Symbol	Parameter	Test conditions	Value	Unit
V_{DSmax}	Drain-Source Voltage	$V_{GS}=0V, I_D=100\mu A$	650	V
V_{GSmax}	Gate-Source Voltage		-10/22	V
V_{GSop}	Recommended Gate-Source Voltage		-5/18	V
I_D	Continuous Drain Current	$V_{GS}=18V, T_C=25^\circ C$	108	A
		$V_{GS}=18V, T_C=100^\circ C$	76	A
$I_{D,pulse}$	Pulsed Drain Current	Pulse width t_p limited by T_{jmax}	161	A
P_{tot}	Power Dissipation	$T_C=25^\circ C, T_j=175^\circ C$	375	W
T_j	Operating Junction Temperature		-55~175	$^\circ C$
T_{stg}	Storage Temperature		-55~175	$^\circ C$

Electrical Characteristics (Defined at $T_j=25^\circ C$ unless otherwise specified)
Static Characteristics

Symbol	Parameter	Test conditions	Value			Unit
			Min.	Typ.	Max.	
$V_{(BR)DSS}$	Drain-Source Breakdown Voltage	$V_{GS}=0V, I_D=100\mu A$	650			V
$V_{GS(th)}$	Gate Threshold Voltage	$V_{GS}=V_{DS}, I_D=17mA$ (tested after 1ms pulse at $V_{GS}=20V$)	2.3	2.7	3.5	V
		$V_{GS}=V_{DS}, I_D=17mA, T_j=175^\circ C$ (tested after 1ms pulse at $V_{GS}=20V$)		1.9		
I_{GSS}	Gate-Source Leakage Current	$V_{GS}=18V, V_{DS}=0V$			100	nA
I_{DSS}	Zero Gate Voltage Drain Current	$V_{DS}=650V, V_{GS}=0V$		1	50	μA
		$V_{DS}=650V, V_{GS}=0V, T_j=175^\circ C$		10	200	
$R_{DS(on)}$	Drain-Source On-State Resistance	$V_{GS}=18V, I_D=50A$		25	40	m Ω
		$V_{GS}=18V, I_D=50A, T_j=175^\circ C$		32		
		$V_{GS}=15V, I_D=50A$		33		
g_{fs}	Transconductance	$V_{DS}=10V, I_D=50A$		22		S

Thermal Characteristics

Symbol	Parameter	Value			Unit
		Min.	Typ.	Max.	
$R_{th(jc)}$	Thermal Resistance from Junction to Case		0.40		K/W

AC Characteristics

Symbol	Parameter	Test conditions	Value			Unit
			Min.	Typ.	Max.	
C_{iss}	Input Capacitance	$V_{GS}=0V, V_{DS}=400V$ $f=100kHz, V_{AC}=25mV$		2450		pF
C_{oss}	Output Capacitance			180		pF
C_{rss}	Reverse Transfer Capacitance			9		pF
E_{oss}	C_{oss} Stored Energy			20		μJ
$C_{O(ER)}$	Effective Output Capacitance, Energy Related	$V_{GS}=0V, 0V < V_{DS} < 400V$		250		pF
$C_{O(TR)}$	Effective Output Capacitance, Time Related	$V_{GS}=0V, 0V < V_{DS} < 400V$		365		pF
$R_{G(int)}$	Internal Gate Resistance	$f=1MHz, V_{AC}=25mV$		1.4		Ω

Gate Charge Characteristics

Symbol	Parameter	Test conditions	Value			Unit
			Min.	Typ.	Max.	
Q_{GS}	Gate to Source Charge	$V_{DS}=400V$ $I_D=50A$ $V_{GS}=-5/+18V$		33		nC
Q_{GD}	Gate to Drain Charge			40		nC
Q_G	Total Gate Charge			98		nC

Switching Characteristics

Symbol	Parameter	Test conditions	Value			Unit
			Min.	Typ.	Max.	
$t_{d(on)}$	Turn-On Delay Time			14		ns
t_r	Rise Time	$V_{DC}=400V, V_{GS}=-5/18V$ $I_D=50A, R_{G(ext)}=15\Omega$		40		ns
$t_{d(off)}$	Turn-Off Delay Time	$L_\sigma=50nH, T_j=25^\circ C$ FWD ¹⁾ : body diode at $V_{GS}=-5V$		49		ns
t_f	Fall Time	Inductive Load Eon includes diode reverse recovery		12		ns
E_{on}	Turn-On Energy(FWD=Body Diode)			365		μJ
E_{off}	Turn-Off Energy(FWD=Body Diode)			210		μJ
E_{on}	Turn-On Energy(FWD=SiC Diode)	$V_{DC}=400V, V_{GS}=-5/18V$ $I_D=50A, R_{G(ext)}=15\Omega$		320		μJ
E_{off}	Turn-Off Energy(FWD=SiC Diode)	$L_\sigma=50nH, T_j=25^\circ C$ FWD ¹⁾ : B3D40065H		210		μJ
$t_{d(on)}$	Turn-On Delay Time			9		ns
t_r	Rise Time	$V_{DC}=400V, V_{GS}=-5/18V$ $I_D=50A, R_{G(ext)}=15\Omega$		37		ns
$t_{d(off)}$	Turn-Off Delay Time	$L_\sigma=50nH, T_j=175^\circ C$ FWD ¹⁾ : body diode at $V_{GS}=-5V$		58		ns
t_f	Fall Time	Inductive Load Eon includes diode reverse recovery		11		ns
E_{on}	Turn-On Energy(FWD=Body Diode)			380		μJ
E_{off}	Turn-Off Energy(FWD=Body Diode)			190		μJ
E_{on}	Turn-On Energy(FWD=SiC Diode)	$V_{DC}=400V, V_{GS}=-5/18V$ $I_D=50A, R_{G(ext)}=15\Omega$		250		μJ
E_{off}	Turn-Off Energy(FWD=SiC Diode)	$L_\sigma=50nH, T_j=175^\circ C$ FWD ¹⁾ : B3D40065H		200		μJ

1) Note: FWD: Freewheeling diode

Reverse Diode Characteristics

Symbol	Parameter	Test conditions	Value			Unit
			Min.	Typ.	Max.	
V_{SD}	Diode Forward Voltage	$V_{GS}=-5V, I_{SD}=25A, T_j=25^{\circ}C$		4.4		V
		$V_{GS}=-5V, I_{SD}=25A, T_j=175^{\circ}C$		3.7		
I_{SD}	Continuous Diode Forward Current	$V_{GS}=-5V, T_c=25^{\circ}C$		60		A
$I_{SD,pulse}$	Pulsed Diode Current	$V_{GS}=-5V$, pulse width t_p limited by T_{jmax}		120		A
t_{rr}	Reverse Recovery Time	$V_{GS}=-5V, V_{DC}=400V, I_{SD}=50A$ $-di_F/dt=2500A/\mu s$ $T_j=25^{\circ}C$		15		ns
Q_{rr}	Reverse Recovery Charge			180		nC
I_{rrm}	Peak Reverse Recovery Current			20		A
t_{rr}	Reverse Recovery Time	$V_{GS}=-5V, V_{DC}=400V, I_{SD}=50A$ $-di_F/dt=3200A/\mu s$ $T_j=175^{\circ}C$		18		ns
Q_{rr}	Reverse Recovery Charge			380		nC
I_{rrm}	Peak Reverse Recovery Current			35		A

Typical Performance

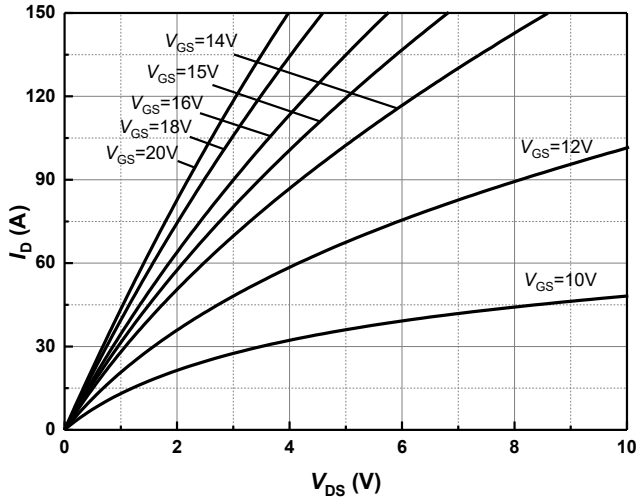

Figure 1 Typical Forward Output Characteristics at $T_j = 25^\circ\text{C}$

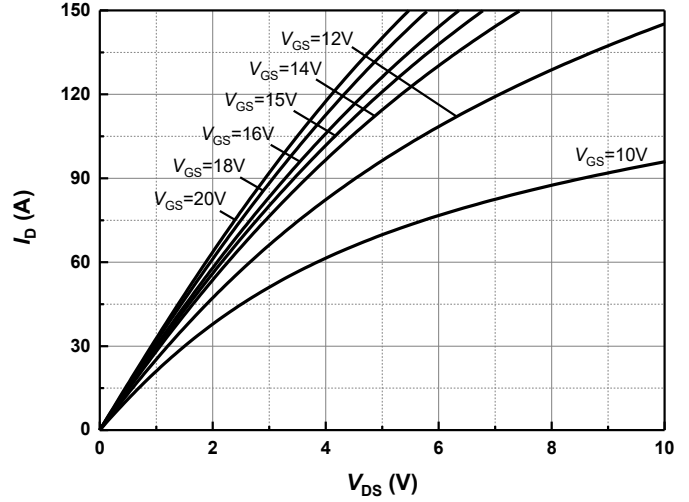

Figure 2 Typical Forward Output Characteristics at $T_j = 175^\circ\text{C}$

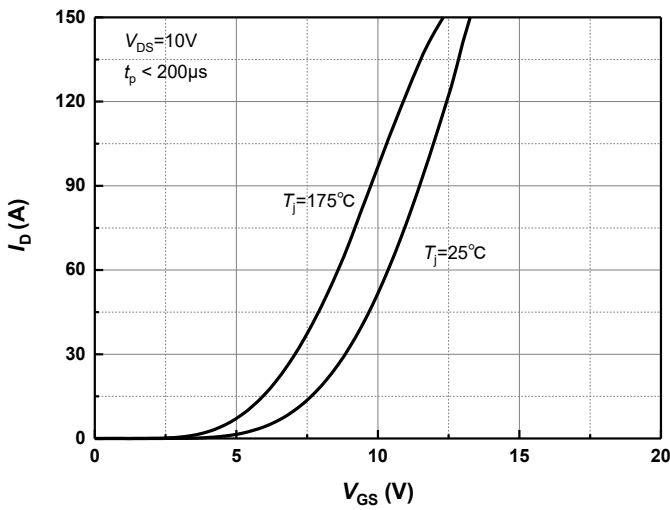

Figure 3 Transfer Characteristics for Various Temperature

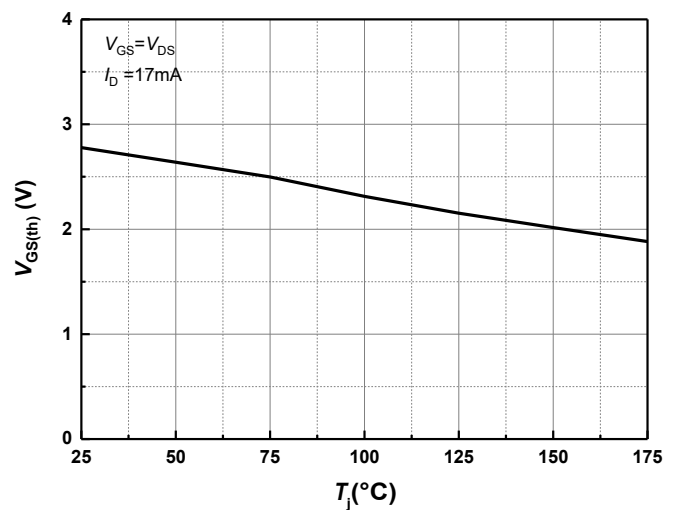

Figure 4 Threshold Voltage for Various Temperature

Typical Performance

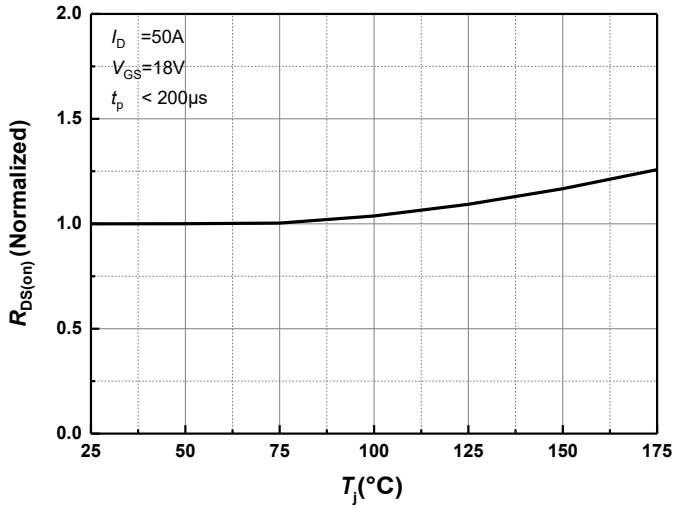

Figure 5 Normalized On-Resistance for Various Temperature

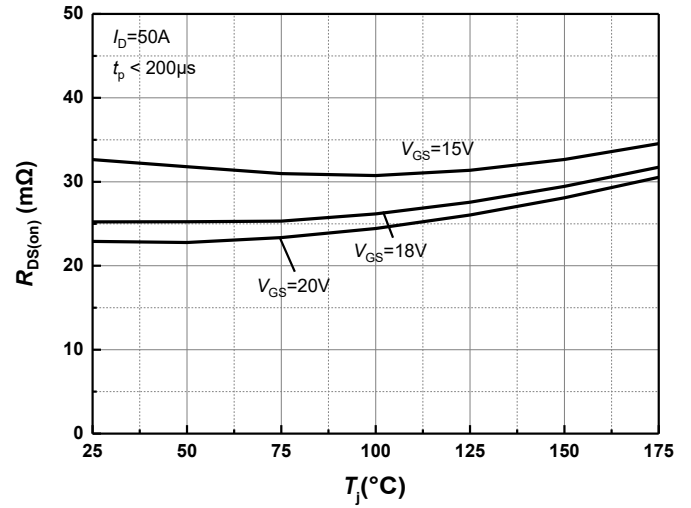

Figure 6 On-Resistance vs. Temperature for Various Gate-Source Voltage

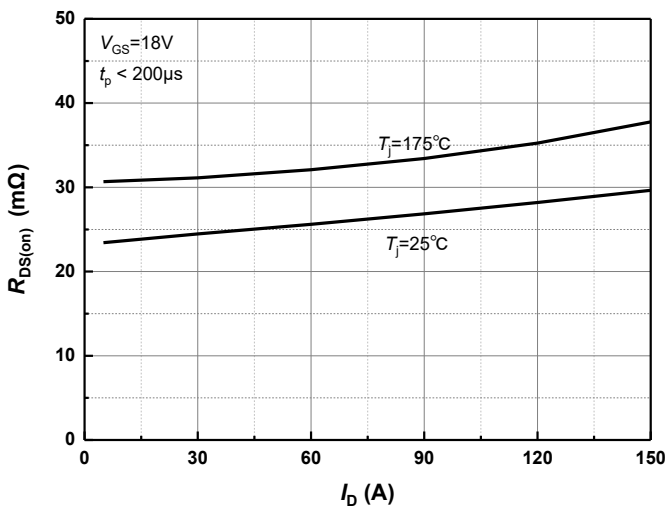

Figure 7 On-Resistance vs. Drain Current for Various Temperature

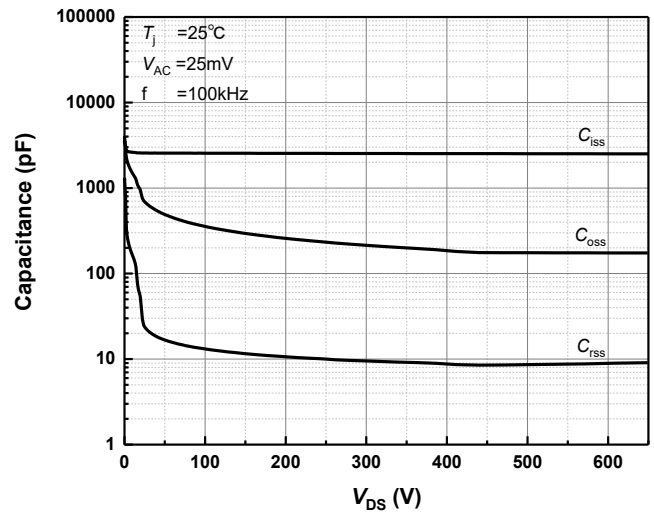

Figure 8 Capacitance vs. Drain-Source Voltage (0 - 650V)

Typical Performance

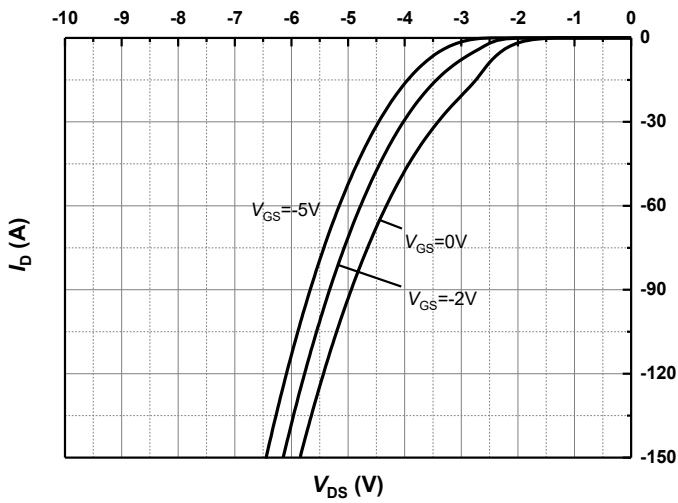

Figure 9 Body Diode Characteristics at $T_j=25^\circ\text{C}$

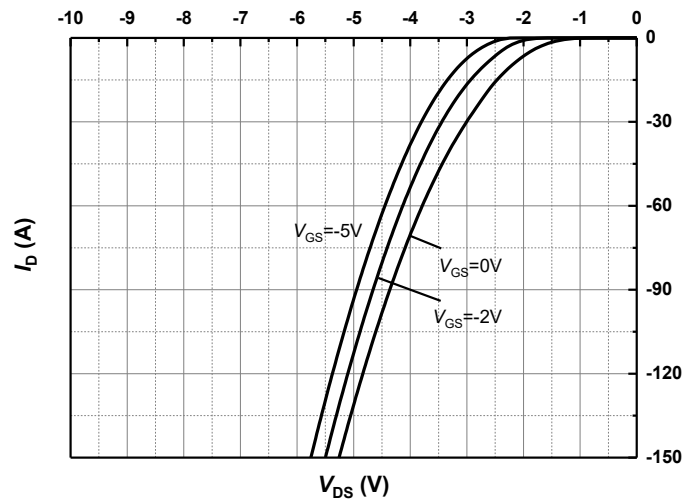

Figure 10 Body Diode Characteristics at $T_j=175^\circ\text{C}$

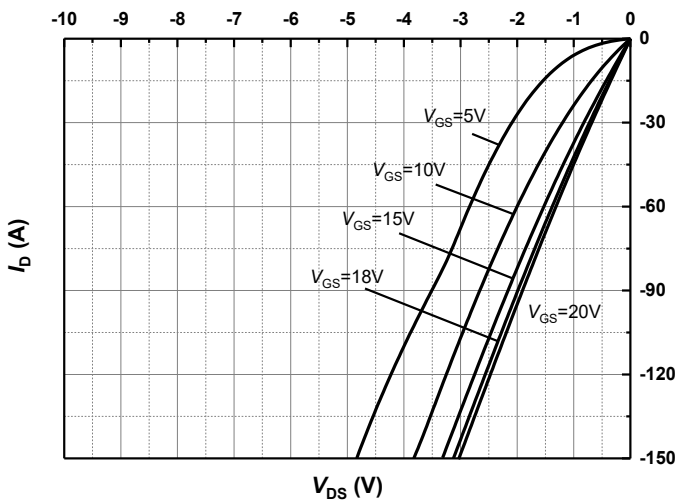

Figure 11 3rd Quadrant Characteristics at $T_j=25^\circ\text{C}$

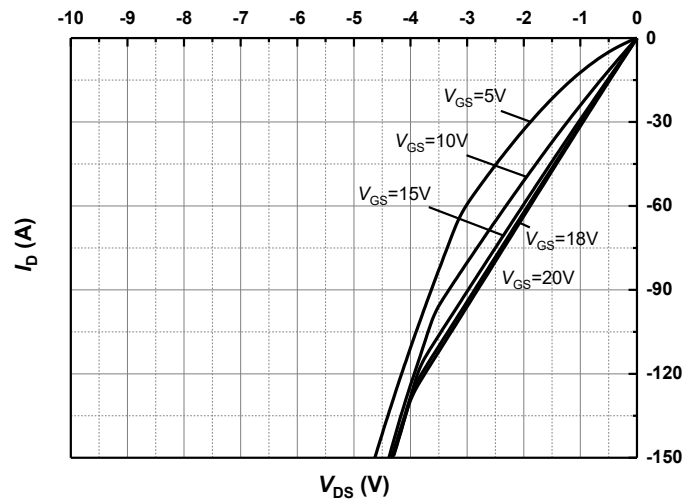

Figure 12 3rd Quadrant Characteristics at $T_j=175^\circ\text{C}$

Typical Performance

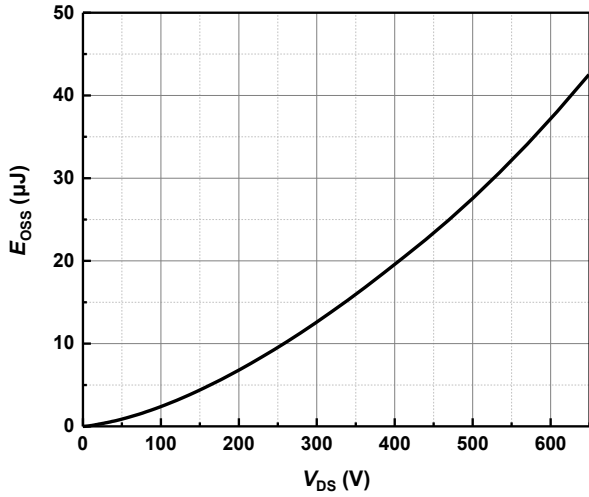

Figure 13 Output Capacitor stored Energy

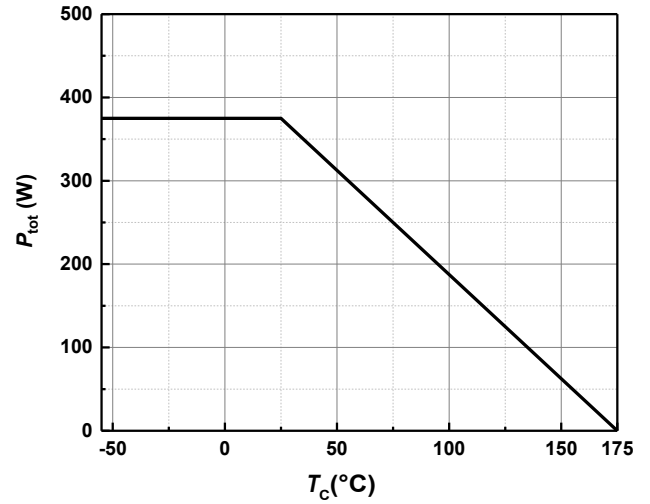

Figure 14 Maximum Power Dissipation Derating vs. Case Temperature

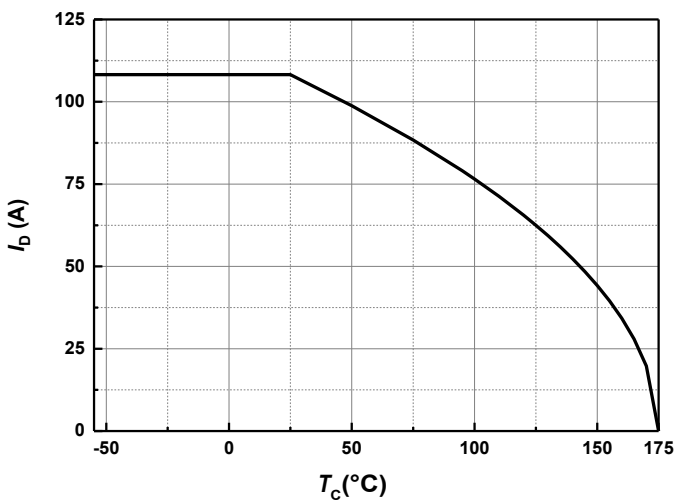

Figure 15 Continuous Drain Current Derating vs. Case Temperature

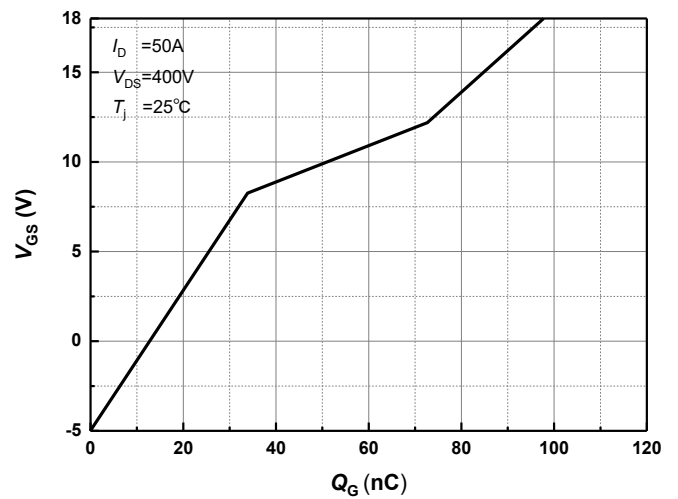

Figure 16 Gate Charge Characteristics

Typical Performance

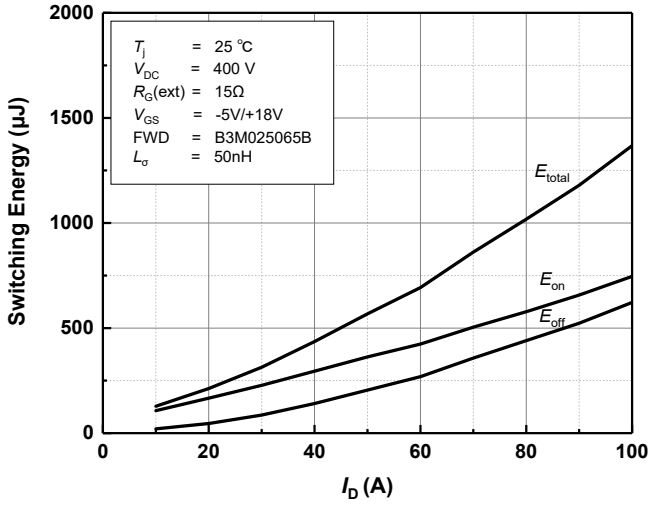

Figure 17 Clamped Inductive Switching Energy vs. Drain Current ($V_{\text{DC}} = 400\text{V}$) at $T_j = 25^\circ\text{C}$

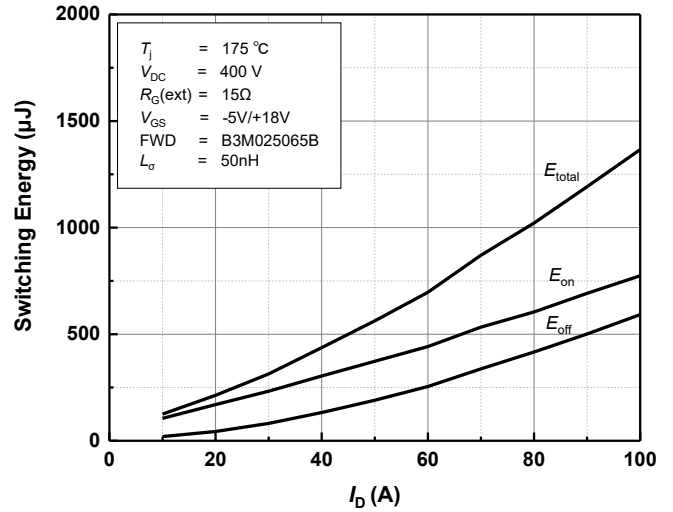

Figure 18 Clamped Inductive Switching Energy vs. Drain Current ($V_{\text{DC}} = 400\text{V}$) at $T_j = 175^\circ\text{C}$

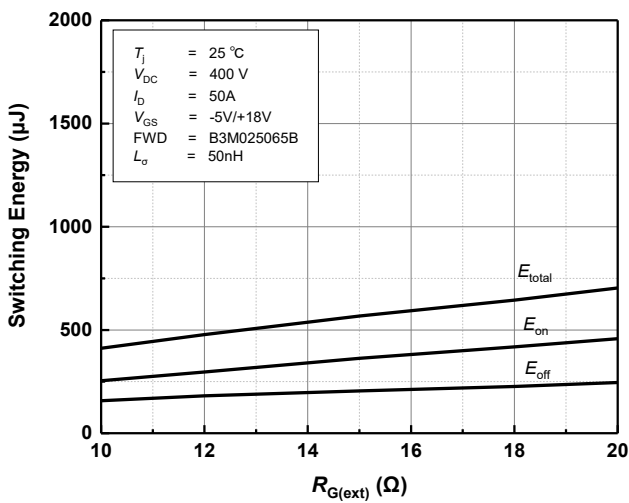

Figure 19 Clamped Inductive Switching Energy vs. External Gate Resistance at $T_j = 25^\circ\text{C}$

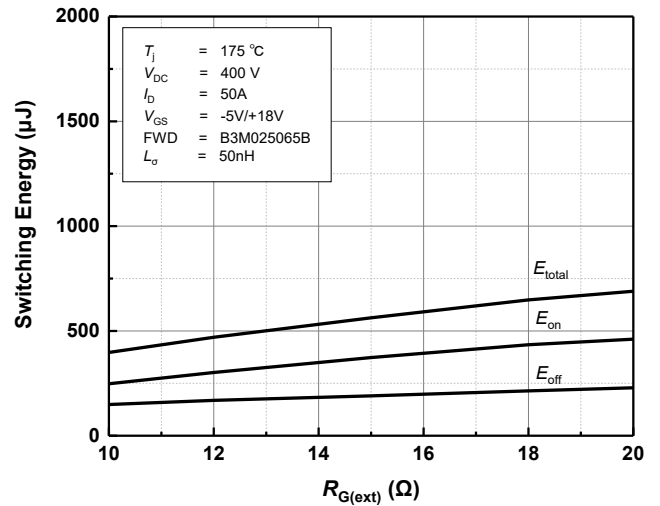

Figure 20 Clamped Inductive Switching Energy vs. External Gate Resistance at $T_j = 175^\circ\text{C}$

Typical Performance

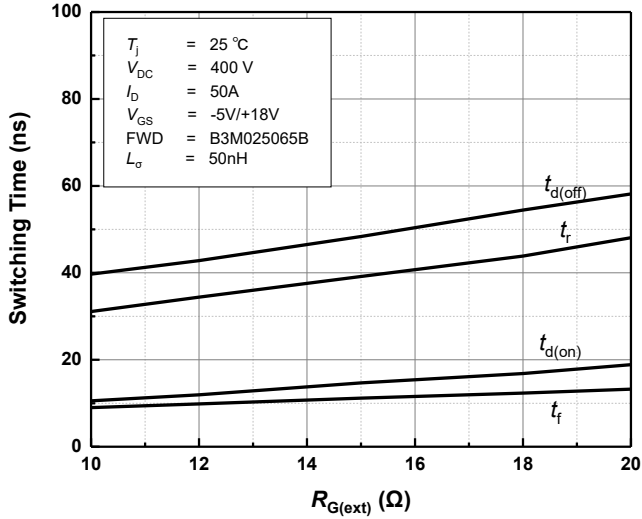

Figure 21 Clamped Inductive Switching Time vs. External Gate Resistance at $T_j=25^\circ\text{C}$

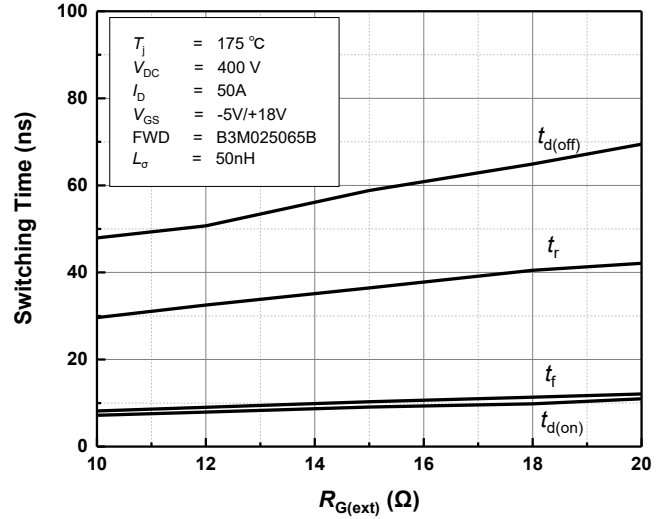

Figure 22 Clamped Inductive Switching Time vs. External Gate Resistance at $T_j=175^\circ\text{C}$

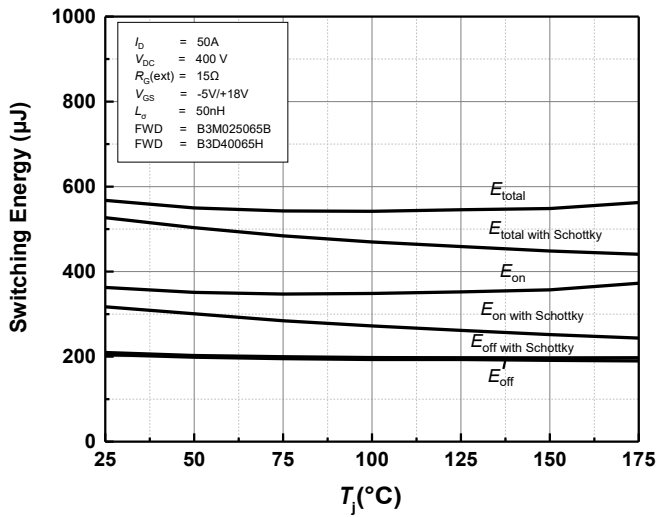

Figure 23 Clamped Inductive Switching Energy vs. Temperature

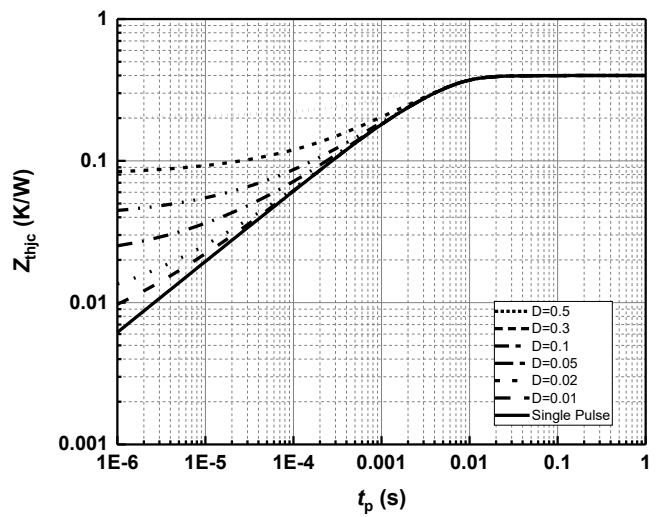

Figure 24 Transient Thermal Impedance (Junction - Case)

Typical Performance

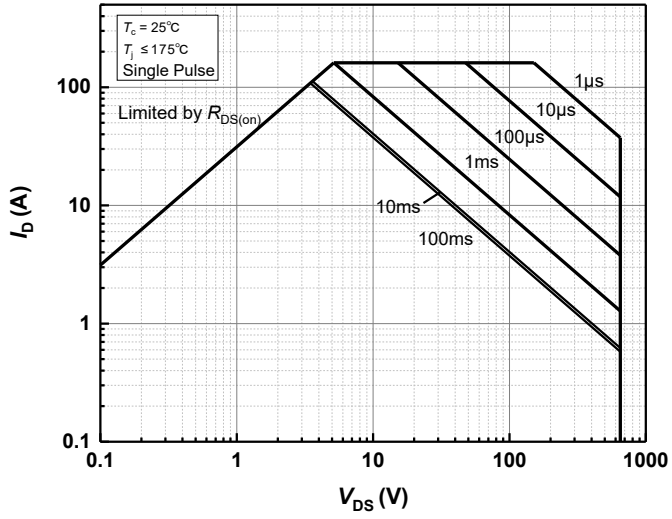
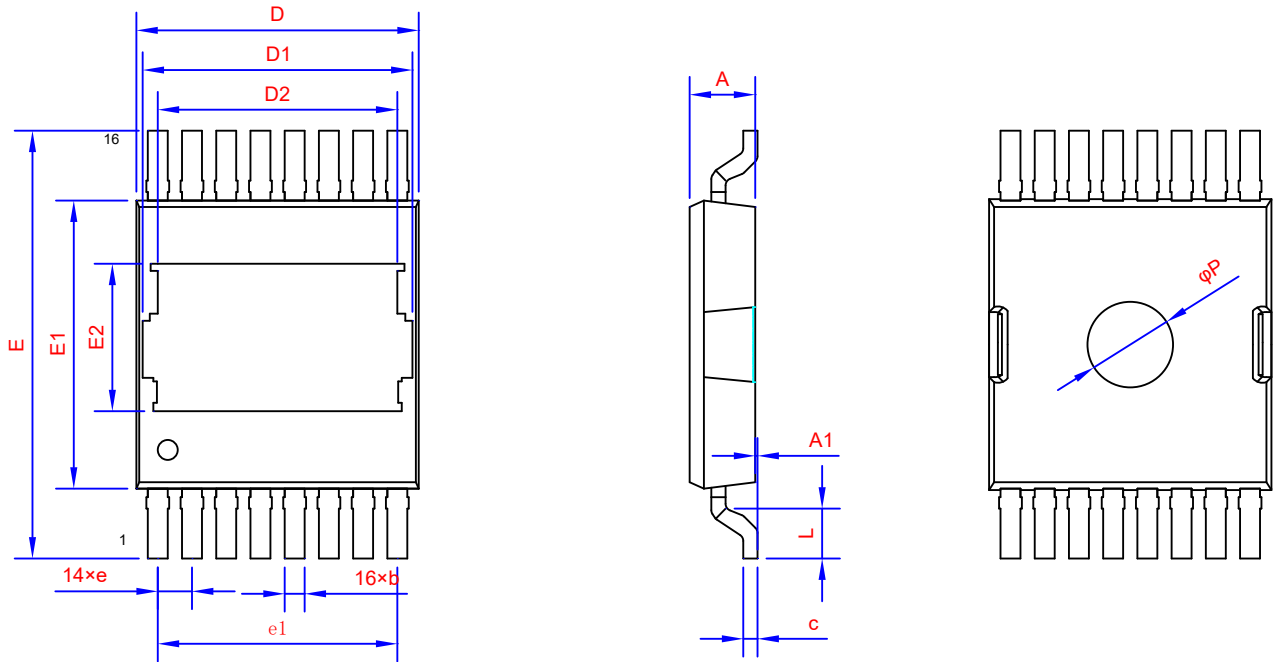

Figure 25 Forward Biased Safe Operating Area

Package Dimensions

SYMBOL	mm		
	MIN	NOM	MAX
A	2.25	2.30	2.35
A1	0.01	0.08	0.16
b	0.60	0.70	0.80
c	0.40	0.50	0.60
D	9.70	9.90	10.10
D1		9.46REF	
D2	8.30	8.40	8.50
E	14.80	15.00	15.20
E1	10.00	10.10	10.30
E2	5.57	5.67	5.77
e	1.10	1.20	1.30
e1	8.30	8.40	8.50
L	1.40	1.50	1.60
P	2.90	3.00	3.10

REF: For reference only, no measurement is required.

Revision History

Document Version	Date of Release	Description of Changes
Rev. 0.0	2025-12-23	Draft datasheet created.

BASiC Semiconductor Co., Ltd.
Shenzhen, China
© 2025 BASiC Semiconductor Co., Ltd.
All Rights Reserved.

Information

For further information on technology, delivery terms and conditions and prices, please contact the nearest BASiC Semiconductor Office.

Disclaimer

The information given in this document shall in no event be regarded as a guarantee of conditions or characteristics. With respect to any examples or hints given herein, any typical values stated herein and / or any information regarding the application of the device, BASiC Semiconductor Co., Ltd. hereby disclaims any and all warranties and liabilities of any kind, including without limitation, warranties of non-infringement of intellectual property rights of any third party.