

RECOMMENDED PANEL CUTOUT  
 MAX. PANEL THICKNESS 1-6mm

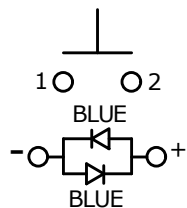

SCHEMATIC  
 SPST - OFF-(ON)  
 ( ) DENOTES MOMENTARY

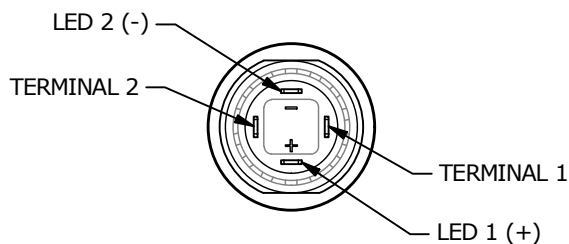
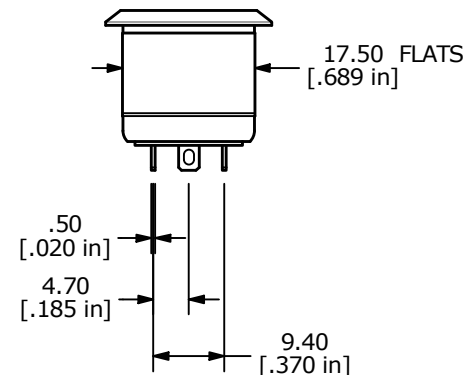
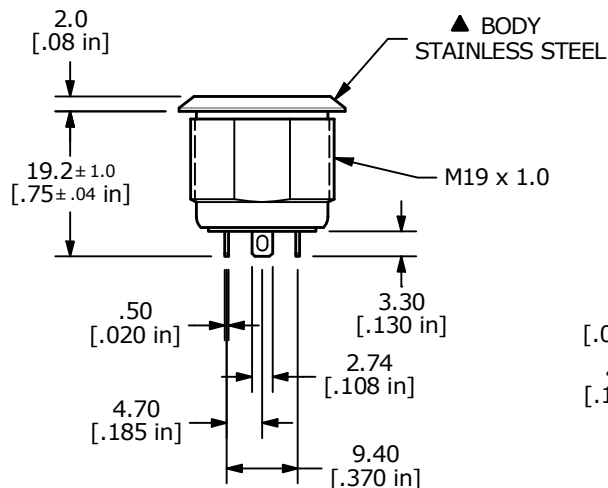
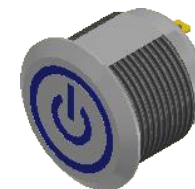
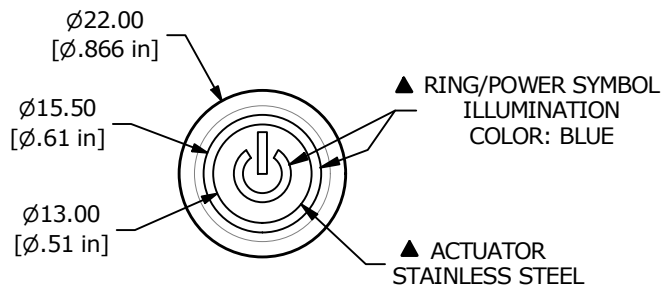

NOTE:

1. ALL DIMENSIONS IN MM [INCH]
2. GENERAL TOLERANCE: X.X = ±0.4  
 X.XX = ±0.25
3. TERMINAL NUMBERS FOR REF ONLY
4. CONTACT MATERIAL: SILVER
5. RATING: 2A 36 VDC
6. ELECTRIC LIFE: 200,000 CYCLES
7. DIELECTRIC STRENGTH: 2,000 VAC MIN. FOR 1 MINUTE
8. CONTACT RESISTANCE: 50mΩ MAX. @ 1A 12VDC
9. OPERATING TEMP.: -20°C to 70°C
11. ▲ DENOTES CRITICAL PARAMETER.
- ▲ 12. LAMP VOLTAGE: BLUE 20mA 3.1V TYP.
13. TRAVEL: 1.80mm
14. ACTUATION FORCE: 4.5 ± 1.5 N
- 15 MOUNTING NUT TORQUE: 1-3 Nm
16. INGRESS PROTECTION: IP67, IK10
17. HARDWARE SUPPLIED: O-RING AND HEXNUT

REV	ECO NO	DESCRIPTION	DATE	BY
C	ECO-101750	print update	03/20/23	MW



OBJECT ID  
 100118659

TITLE SV4F23SS-641				
SCALE 1:1	DATE 9/22/2021	DR MW	DWG T840006	REV C